

引领中国泵工业的崛起

第六代KQL/KQW系列立式/卧式 单级单吸离心泵

Generation-6KQL/KQW Series Single Stage
Vertical / horizontal Centrifugal Pump

引领中国泵工业的崛起



结构紧凑、合理

泵与电机直接连接，外形美观，占地面积小

效率高

闭式铸铁叶轮，优秀的水力模型保证泵的高效和节能，大部分型号泵的配套功率下降一档

可靠性强

SKF 轴承配置合理，叶轮悬臂端，机泵轴完全同心，泵运行平稳、可靠，噪音低

寿命长

密封位不锈钢，永不生锈，强制环流冲洗进口品牌机械密封，免保养、无渗漏、3年免维护



上海凯泉泵业(集团)有限公司
SHANGHAI KAIQUAN PUMP(GROUP) CO., LTD.

公司地址：上海市嘉定区曹安公路4255、4287号

公司网站：www.kaiquan.com.cn

客服热线：400-002-6600



YB/KQ KQL/KQW 2020/03



SKF Equipped



ISO9001 2015 版国际质量体系认证
ISO9001 2015 Certified (Version 2015)

凯泉与SKF战略合作

SKF根植中国，凯泉走向世界！

斯凯孚（SKF）商标使用授权书

授权方：斯凯孚（中国）销售有限公司

兹授权：上海凯泉泵业（集团）有限公司及其下属分公司

允许在其生产的装配有SKF产品的工业泵系列产品（具体产品系列及型号详见协议附件）上使用“SKF Equipped”商标。详细条款请见双方签署的“商标使用协议”



授权时间：2017年11月1日

授权地点：上海



© SKF Group

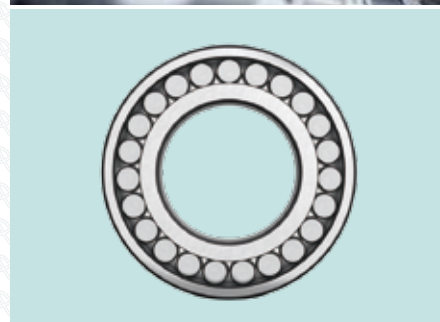

凯泉成为全球率先允许在设备上使用SKF Equipped商标的企业！

上海凯泉是集设计/生产/销售泵、给水设备及泵用控制设备于一体的大型综合性泵业集团，是中国泵行业的龙头企业。集团现有员工4500多人，其中工程技术人员750多名，主要由知名水泵专家教授、博士硕士、中高级工程师构成，形成了具有创新思维的梯队人才结构。在上海、浙江、河北、辽宁、安徽等省市拥有7家企业，5个工业园区。上海凯泉集团获得了“上海市科技百强企业”、“上海市名牌产品”、“中国质量信用AAA级”、“全国合同信用等级AAA级”、“质量、信誉、服务三优企业”、“中国最具竞争力的商品商标”等光荣称号。产品服务于建筑（包含热力及空调）、市政、核电、火电、石油化工、大型水利等领域。

斯凯孚集团不断致力于减小摩擦,使机械设备的运行速度更快,使用寿命更长,更环保和更安全。秉承高效和可持续性的经营理念,斯凯孚集团是滚动轴承、密封件、机电一体化、服务和润滑系统领域全球领先的产品、解决方案和服务供应商。服务包括技术支持、维护服务、状态监测、资产效率优化、工程咨询和培训。

时至今日,斯凯孚在全球拥有130多座生产基地,销售公司遍布130多个国家,有超过17,000家经销商店,为世界各地客户提供符合全球质量标准的定制化解决方案和产品。

目 录

| | |
|--------------------|----|
| 一、用途 | 01 |
| 二、使用说明 | 01 |
| 三、型号说明 | 01 |
| 四、材质 | 01 |
| 五、结构 | 02 |
| 六、电机 | 02 |
| 七、泵机组优点 | 02 |
| 八、供货范围 | 03 |
| 九、订货须知 | 03 |
| 十、型谱图 | 04 |
| 十一、KQL结构图 | 05 |
| 十二、KQW结构图 | 05 |
| 十三、性能曲线图、参数表、安装尺寸图 | 06 |
| 十四、附件及安装基础尺寸图标 | 44 |
| 十五、KQL泵的安装方式 | 45 |
| 十六、与原型号对照表 | 47 |

用途Applications

用于空调、采暖、卫生用水、水处理、冷却冷冻系统,液体循环和供水、增压及灌溉等领域中无腐蚀的冷水和热水输送。介质固体不溶物,其体积不超过单位体积0.1%, 粒度 < 0.2mm
Sending non-corrosive cold and warm water used in air-condition, heat circulation, freezing water system, water supply, press increased and irrigation. The volume should not exceed the unit volume by 0.1% and particle size should be less than 0.2mm.

| 泵送液体 | 使用温度 | 机械密封材质 |
|------|--------------------|-------------------------|
| 水 | 地下水 | <80°C AQ2EFF |
| | 锅炉给水 | <80°C AQ2EFF |
| | 冷凝水 | <120°C AQ2VFF |
| | 区域供暖用水 | <80°C Q2Q2EFF |
| | 软化水 | 80~120°C AQ2VFF |
| | 含油水 | <80°C Q2Q2VFF |
| | 软化和切削润滑剂 | <80°C Q2Q2EFF |
| 冷却剂 | 醇类化合物(液体) | <50°C 40% Q2Q2EFF |
| | 30%盐水(如氯化钠、氯化钙等溶液) | <5°C Q2Q2EFF |

例如:

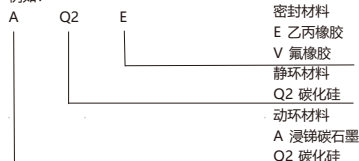

使用条件Working conditions

转速: 2960r/min, 1480r/min, 980r/min
流量范围: 8~1400m³/h
扬程: ≤127m
介质温度: -10°C~80°C
80°C~120°C (耐高温机封、轴承、O形密封圈)
环境温度: 最大+40°C; 海拔高度小于1000m; 相对湿度不超过95%
最大工作压力(承压):

| 型号 | 工作压力 | 测试压力 | 承压零件材质 |
|---------------------|--------|--------|-----------|
| 125口径(2极转速)及125口径以下 | 1.6MPa | 2.1MPa | 灰铁 |
| 125~250口径(4极转速) | 1.2MPa | 1.6MPa | 灰铁 |
| 300口径及300口径以上 | 1MPa | 1.3MPa | 灰铁 |
| 125口径(4极转速)及125口径以上 | 1.6MPa | 2.1MPa | 球铁, 订货需注明 |

最大工作压力=进口压力+闭阀压力(Q=0)
最大进口压力

| 型号 | 扬程(m) | 最大进口压力(MPa) | |
|---------------------|-------|-------------|-----------|
| | | 标准配置 | 球铁泵壳、高压机封 |
| 125口径(2极转速)及125口径以下 | ≤ 40 | 1.2 | / |
| | ≤ 60 | 1 | / |
| | ≤ 80 | 0.8 | / |
| | ≤ 125 | 0.4 | / |
| 125~250口径(4极转速) | ≤ 20 | 1 | / |
| | ≤ 40 | 0.8 | 1.2 |
| | ≤ 60 | 0.6 | 1 |
| | ≤ 80 | 0.4 | 0.8 |
| 300口径及300口径以上 | ≤ 20 | 0.8 | 1.2 |
| | ≤ 40 | 0.6 | 1.2 |
| | ≤ 60 | 0.4 | 1 |
| | ≤ 80 | 0.2 | 0.8 |

125口径(2极转速)及125口径以下小口径泵无需采用球铁材质, 表中打“/”号配置公司不再生产。

汽蚀余量是设计点实测值, 实际使用时应加0.5m的安全裕量。可选配PN16-GB/T17241.6-2008配对法兰。

Speed: 2960r/min, 1480r/min or 980r/min

Capacity range: 1.8~2000m³/h

Head: Up to 127m

Medium temperature: -10°C~ 80°C

Ambient temperature: Up to + 40°C;

Altitude < 1000m; relative humidity ≤ 95%

Maximum working pressure:

Suction and discharge diameters are 125mm (2 pole speed) and below 125mm: 1.6Mpa;

Suction and discharge diameters are 125mm (4 pole speed) and 150-250mm: 1.2Mpa;

Suction and discharge diameters are greater than or equal to 300mm: 1.0Mpa;

Maximum operation pressure=Inlet pressure+valve shutting pressure.

型号说明Definition

例如: 80KQL50-32-7.5/2或80KQW50-32-7.5/2

KQL 标准立式单级泵, KQW 标准卧式单级泵

80 进出口直径

50 额定点流量

32 额定点扬程

7.5/2 电机功率/电机极数

For example: 80KQL50-32-7.5/2 or 80KQW50-32-7.5/2

KQL: Standard vertical single-stage pump

KQW: Standard horizontal single-stage pump

80: Suction and discharge nozzle nominal diameters

50: Capacity at rated point

32: Head at rated point

7.5/2: Motor power/motor pole

| 主要部件 MAIN PARTS | 型号配置 MODEL | KQL 或 KQW | KQL/T 或 KQW/T |
|-------------------------|---|-----------|--|
| 电机系列 MOTOR | YE2 系列超高效率三相异步电动机 Three-phase induction motor series | | 按用户要求 According to the customer's needs |
| 泵轴材料 SHAFT | 45# 钢 45# | | |
| 轴套材料 Shaft sleeve | 304 | | |
| 轴承 BEARING | 进口名牌 SKF | | |
| 机械密封 MECHANICAL SEAL | 品牌 (35 轴径及以下为国内知名品牌, 45 轴径及以上为进口品牌) famous brand | | |
| 铸件 CASTING | 优质铸件 Quality casting | | |
| 表面处理 SURFACE DISPOSE | 电泳漆 | | |

材质Materials

泵体、泵盖、叶轮: 铸铁

泵轴: 45#钢

机械密封动、静环: 浸钨石墨、碳化硅

Materials

Casing, Cover, Impeller: Cast iron

Shaft: 45#

Motive, motionless ring of mechanical seal: Graphite, harden alloy

结构Structure

结构紧凑的单级泵，是最适用于现代建筑物的。

Compact single-stage pump is especially suitable for modern

——立式泵壳

管理连接型式的螺旋形泵壳，采用现代最优水力模型设计制造，进出口在同一直线上，且口径相同。法兰符合GB/T17241.6-2008并可选配Rp1/4或Rp3/8测压口。

——Casing

It has pipe joined spiral casing and uses the best hydraulic model. Suction and discharge nozzles are in one line with the same diameter. Flange accords with the standard of GB/T17241.6-1998 and may choose to be fixed with Rp1/4 or Rp3/8 pressure gauge.

——卧式泵壳

泵脚支承型式的螺旋形泵壳，采用现代最优水力模型设计制造，水平吸入，上方输出，且口径相同。法兰符合GB/T17241.6-2008并可选配Rp1/4或Rp3/8测压口。

——Casing

It has pipe joined spiral casing and uses the best hydraulic model. Suction and discharge nozzles are in one line with the same diameter. Flange accords with the standard of GB/T17241.6-1998 and may choose to be fixed with Rp1/4 or Rp3/8 pressure gauge.

——叶轮

闭式叶轮，优秀的水力模型保证泵的效率 and 可靠性，部分改进型号泵的配套功率下降一档。

——Impeller

Closed cast iron impeller. Best hydraulic model guarantees the efficiency and reliability of the pump.

机械密封Mechanical seal

系列产品

用于水温80℃以下免保养，并不受转向限制。特殊波纹管设计保证了动环的补偿性和密封性能。

Series product.

If the pump operates in the water with temperature below 80℃, it needn't maintain and will not be limited by rotating direction. Special bellows design guarantees the compensation and hermetic function of the dynamic ring.

电机Motor

YE2系列超高效率三相异步电动机系列。功率和型式符合IEC-Norm.

型式: V1 (KQL) B35 (KQW)

电源: 380V, 50HZ

防护等级: IP55

绝缘等级: F

电机轴: 45#钢(密封位304) 或不锈钢(2Cr13)

温度: 电机工作环境温度最大到40℃。温度高于40℃时, 请降低功率使用。

转向: 立式泵从电机风叶端向下看为顺时针方向, 卧式泵从泵进口方向看为逆时针方向。

Squirrel three-phase induction motor series.

Efficiency and type accord with ICE-Norm.

Type: V1 (KQL) B35 (KQW)

Power source: 380V, 50HZ

Protection class: IP55

Insulation: F

Shaft of the motor: Stainless steel(2Cr13)

Temperature: Maximum temperature of working environment is 40℃. Above 40℃, please decrease the power.

泵机组优点Advantages

——采用电机直接连接，机泵轴完全同心，振动小、噪音低

——泵进出口口径相同，运行稳定可靠。

——用整轴和特殊结构配置的SKF轴承，运行可靠。

——用强制环流的不受转向限制的特殊结构配置的机械密封，改善其运行环境，延长使用寿命。

——独特的安装结构大大缩小了泵的占地面积，节约建设投资40%~60%。

——完美的设计确保泵的无泄漏，长寿命运行，节约运行管理费50%~70%。

——采用优质铸件，尺寸精度高，外形美观。

电机优点：

——采用更新设计的超高效率三相异步电动机系列，结构更加合理，外形新颖美观。

——启动转矩大，效率高，噪音小。

——F级绝缘，提高了电机使用的最高允许温升，因而抗过载能力高，耐力强，使用安全可靠，寿命延长。

——IP55全封闭结构，防止粉尘、风雨、飞溅水滴等进入电机内部，造成电机损坏。

——密封位不锈钢，永不生锈，保证配合零件拆装简便，机械密封波纹管密封可靠。

-Directly connected with the motor. the axle of motor and pump share the same shaft. Less vibration, Low noise.

-The outlet and inlet are same in diameter and the diameters are in the same line. Liquid flows smoothly with less loss.

-Removal of baseplate. Just like valves, the pump can be mounted wherever on the pipe line.

-The whole shaft and special structured configuration bearing runs reliably.

-The mechanical seal, which applies the configuration of enforced circulation and no direct-ionlimited special structure, improves the running environment and elongate the service life.

-Unique in stallation reduces the occupation of pump, which saves the invest cost by 40% to 60%.

-Perfect design makes sure of no leakage, long life, which saves operation cost by 50% to 70%.

-Adopt the high-quality casting off, which results in high accuracy in dimension and nice-looking appearance.

Motor Advantages

-Adopt the modified Two-phase induction, the structure is more reasonable and, rational and nice-looking.

-The starting torque is large, the efficiency is high, the noise is low.

-F class insulation, which improves the permissible temperature rise of motor, thus resulting in high ability the antioverload, strong wear-resistant, and long service life.

-Ip 55 fully close structure, which prevents dust, water drop, rain (with cover) from entering the motor to damage the motor.

-Rotating shaft made of stainless material; will never be rusty, which ensures that the components are easy to dismantle, and the ripple pipe of mechanical seal is reliable.

供货范围Supply Arrange

水泵带底座（板）和安装使用说明书

Pump and installation instructions are available.

订货须知Notes on Order-placing

1. 输送特殊液体时，请在合同中注明液体的名称。温度、密度、浓度、粘性等，以便制造厂合理选配材质和电机功率。

2. 当对流量、扬程、进口压力、电机电压、频率、防爆等有特殊要求时，请在合同中注明。

1. Name, temperature, density, concentration, trellises should be clearly noted in the contract when the transporting media is corrosive, so that the manufacturer can make a proper choice of material and power of motor.

2. It should be clearly noted in the contract when special requirement, for instance, capacity, suction pressure, head, motor, voltage, frequency, blast-proof etc, are made.

型谱图HYDRAULIC COVEAGE

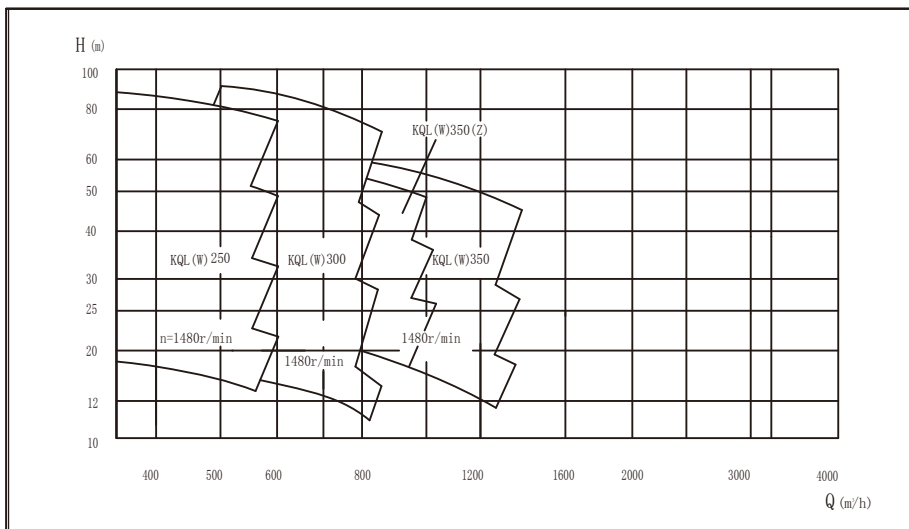
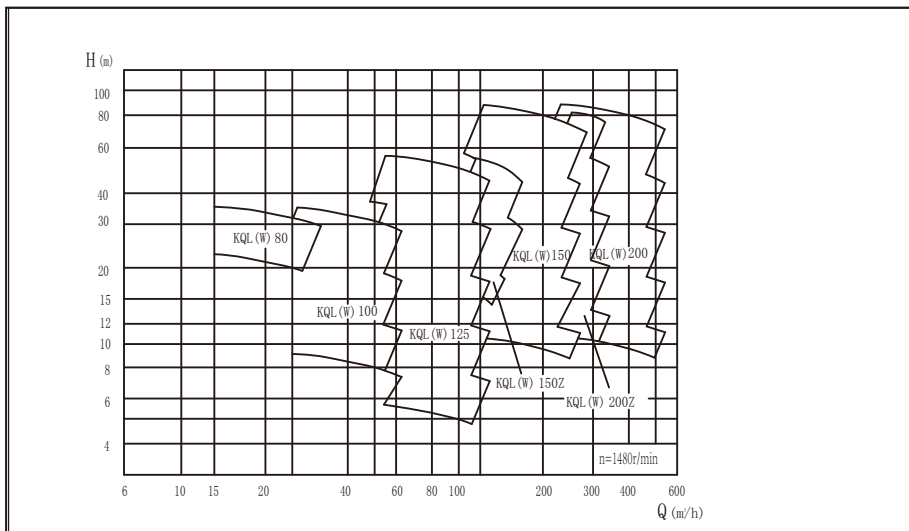
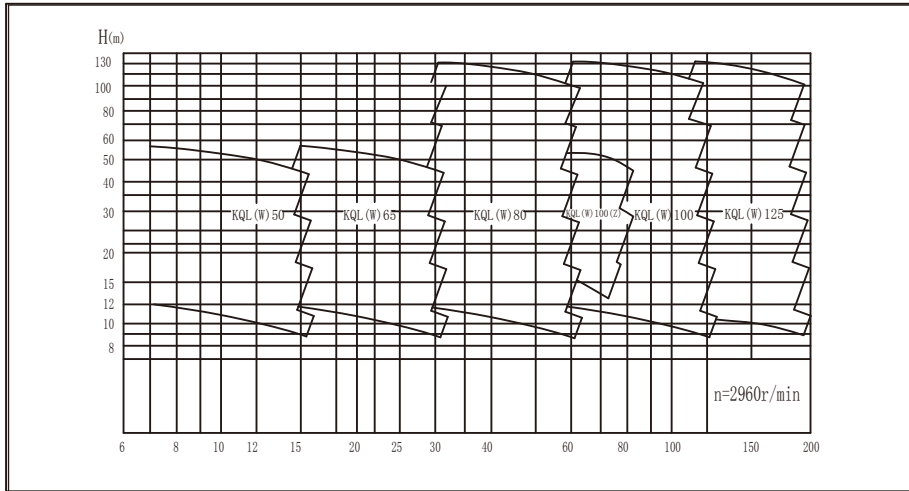

KQL结构图KQL STRUCTURE DRAWING

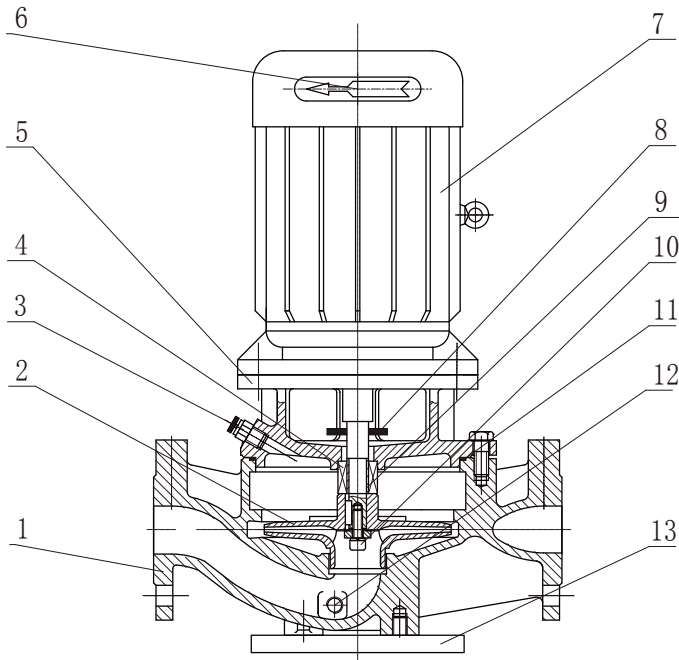

| 序号 No. | 数量 QUANTITY | 名称 NAME |
|-----------|----------------|---------------------------|
| 1 | 1 | 泵体 Casing |
| 2 | 1 | 叶轮 Impeller |
| 3 | 1 | 放气旋塞 Air discharge valve |
| 4 | 1 | 机械密封 Mechanical seal |
| 5 | 1 | 泵盖 Casing cover |
| 6 | 1 | 转向牌 Chang direction plate |
| 7 | 1 | 电机 Motor |
| 8 | 1 | 挡水圈 Deflector |
| 9 | 1 | 不锈钢轴套 Shaft sleeve |
| 10 | 1 | 螺钉 Screw |
| 11 | 1 | O形密封圈 O seal ring |
| 12 | 1 | 螺塞 Plug |
| 13 | 1 | 底板 Baseplate |

KQW结构图KQW STRUCTURE DRAWING

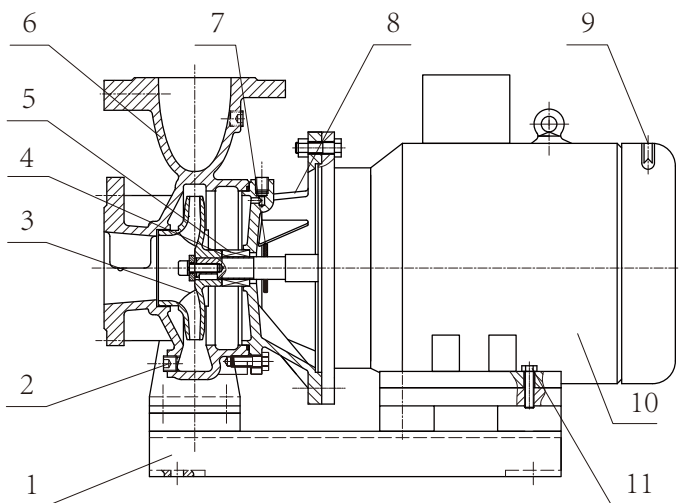

| 序号 (NO.) | 数量 QUANTITY | 名称 NAME |
|-------------|----------------|---------------------------|
| 1 | 1 | 底座 Bedplate |
| 2 | 3 | 螺塞 Screwed plug |
| 3 | 1 | 叶轮 Impeller |
| 4 | 1 | 不锈钢轴套 Shaft sleeve |
| 5 | 1 | 机械密封 Mechanical seal |
| 6 | 1 | 泵体 Pump body |
| 7 | 1 | 挡水圈 Deflector |
| 8 | 1 | 泵盖 Pump Cover |
| 9 | 1 | 转向牌 Chang direction plate |
| 10 | 1 | 电动机 Motor |
| 11 | 8 | 螺栓 Bolt |

性能曲线 CHARACTERISTIC CURVE

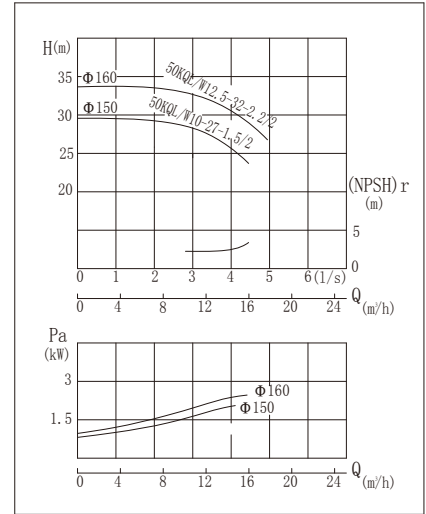
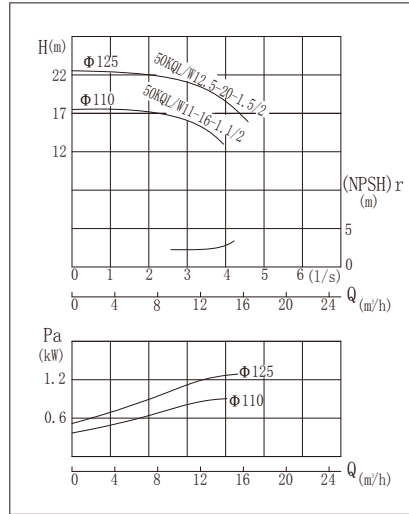
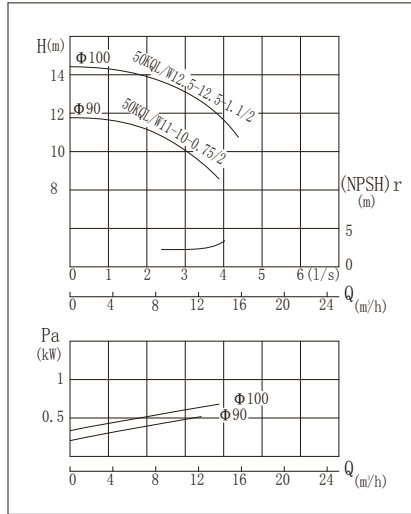

尺寸图 DIMENSION FIGURE

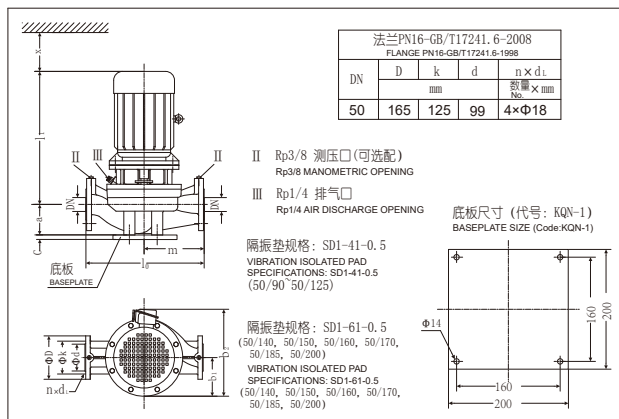

KQL尺寸表 DIMENSION TABLE

| 型号 TYPE | DN | l ₀ | m | a | c | l ₁ | b ₁ | b ₂ | x |
|----------------------|----|----------------|-----|-----|----|----------------|----------------|----------------|-----|
| | | mm | | | | | | | |
| 50KQL11-10-0.75/2 | 50 | 370 | 185 | 115 | 24 | 395 | 120 | 265 | 100 |
| 50KQL12.5-12.5-1.1/2 | 50 | 370 | 185 | 115 | 24 | 395 | 120 | 265 | 100 |
| 50KQL11-16-1.1/2 | 50 | 370 | 185 | 115 | 24 | 395 | 120 | 265 | 100 |
| 50KQL12.5-20-1.5/2 | 50 | 370 | 185 | 115 | 24 | 440 | 155 | 280 | 100 |
| 50KQL10-27-1.5/2 | 50 | 370 | 185 | 115 | 24 | 440 | 120 | 280 | 100 |
| 50KQL12.5-32-2.2/2 | 50 | 370 | 185 | 115 | 24 | 470 | 120 | 280 | 100 |
| 50KQL10-36-3/2 | 50 | 380 | 190 | 127 | 24 | 513 | 155 | 325 | 120 |
| 50KQL12-44-4/2 | 50 | 380 | 190 | 127 | 24 | 548 | 155 | 345 | 120 |
| 50KQL12.5-50-5.5/2 | 50 | 380 | 190 | 127 | 24 | 578 | 185 | 400 | 120 |

性能曲线CHARACTERISTIC CURVE

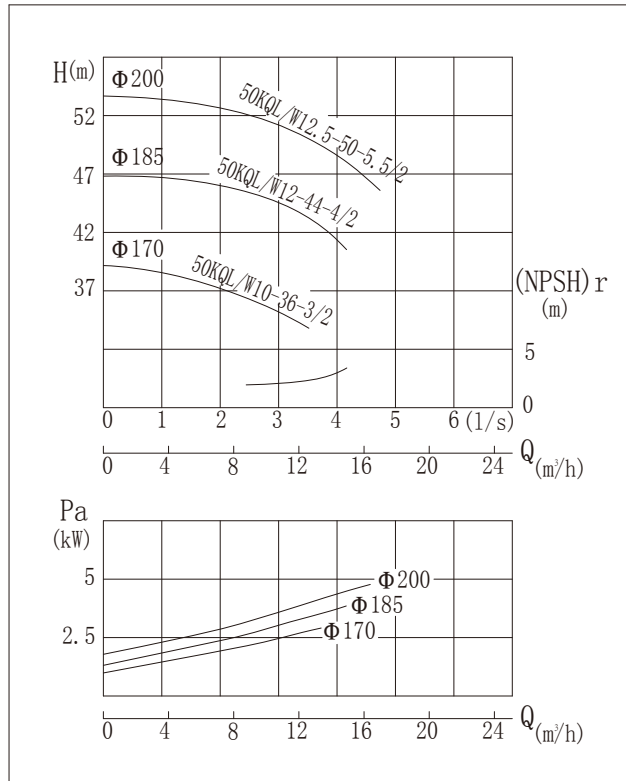

参数表PERFORMANCE DATA

| 型号 TYPE | 流量 Capacity | | 扬程 Head (m) | 转速 Speed (r/min) | 效率 Efficiency (%) | 电机 功率 Power (kW) | 必需汽蚀 余量 (NPSH) _r (m) | 重量 Weight (kg) |
|------------------------|----------------|-------|-------------------|------------------------|-------------------------|---------------------------|--|----------------------|
| | (m³/h) | (l/s) | | | | | | |
| 50KQL/W11-10-0.75/2 | 8 | 2.22 | 11 | 2960 | 66 | 0.75 | 2.3 | 38 |
| | 11 | 3.05 | 10 | | | | | |
| | 13.2 | 3.67 | 9 | | | | | |
| 50KQL/W12.5-12.5-1.1/2 | 8.8 | 2.44 | 13.6 | 2960 | 66.2 | 1.1 | 2.3 | 40 |
| | 12.5 | 3.47 | 12.5 | | | | | |
| | 15 | 4.17 | 11.3 | | | | | |
| 50KQL/W11-16-1.1/2 | 8 | 2.22 | 17 | 2960 | 61 | 1.1 | 2.3 | 40 |
| | 11 | 3.05 | 16 | | | | | |
| | 13.2 | 3.67 | 14 | | | | | |
| 50KQL/W12.5-20-1.5/2 | 8.8 | 2.44 | 21.5 | 2960 | 62.1 | 1.5 | 2.3 | 48 |
| | 12.5 | 3.47 | 20 | | | | | |
| | 15 | 4.17 | 17.8 | | | | | |
| 50KQL/W10-27-1.5/2 | 7.0 | 1.94 | 28.35 | 2960 | 55 | 1.5 | 2.3 | 51 |
| | 10 | 2.78 | 27 | | | | | |
| | 11.0 | 3.06 | 26.2 | | | | | |
| 50KQL/W12.5-32-2.2/2 | 8.8 | 2.43 | 33.6 | 2960 | 56 | 2.2 | 2.3 | 59 |
| | 12.5 | 3.47 | 32 | | | | | |
| | 13.8 | 3.82 | 30 | | | | | |
| 50KQL/W10-36-3/2 | 7.3 | 2.02 | 38 | 2960 | 48 | 3 | 2.3 | 65 |
| | 10.4 | 2.89 | 36 | | | | | |
| | 12.5 | 3.47 | 33 | | | | | |
| 50KQL/W12-44-4/2 | 8.3 | 2.31 | 45.8 | 2960 | 49 | 4 | 2.3 | 80 |
| | 11.7 | 3.25 | 44 | | | | | |
| | 14.0 | 3.89 | 42 | | | | | |
| 50KQL/W12.5-50-5.5/2 | 8.8 | 2.43 | 52 | 2960 | 49.5 | 5.5 | 2.3 | 105 |
| | 12.5 | 3.47 | 50 | | | | | |
| | 15.0 | 4.17 | 48 | | | | | |

尺寸图DIMENSION FIGURE

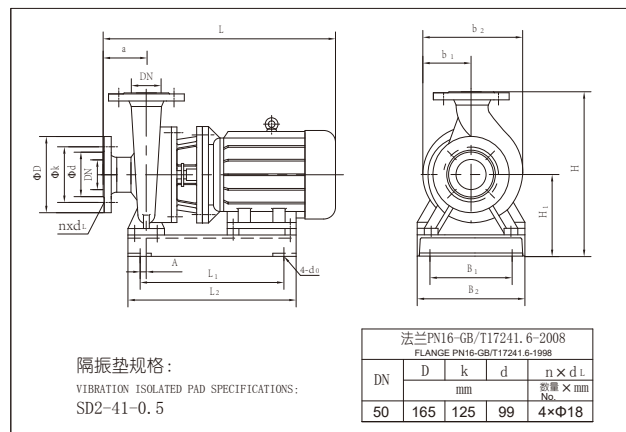

KQW尺寸表DIMENSION TABLE

| 型号 TYPE | 外形尺寸 Figure dimensions | | | | 安装尺寸 Installing dimensions | | | | | | | | DN |
|--------------------|---------------------------|-----|----------------|----------------|-------------------------------|-----|----------------|----------------|----------------|----------------|----------------|------|----|
| | L | H | b ₂ | b ₁ | 4-φ ₀ | a | L ₁ | B ₁ | L ₂ | B ₂ | H ₁ | A | |
| 50KQW11-10-0.75/2 | 475 | 379 | 250 | 125 | 4-φ12 | 80 | 245 | 160 | 345 | 250 | 219 | 0 | 50 |
| 50KQW12.5-12.5-1.1 | 475 | 379 | 250 | 125 | 4-φ12 | 80 | 245 | 160 | 345 | 250 | 219 | 0 | 50 |
| 50KQW11-16-1.1/2 | 475 | 379 | 250 | 125 | 4-φ12 | 80 | 245 | 160 | 345 | 250 | 219 | 0 | 50 |
| 50KQW12.5-20-1.5/2 | 520 | 379 | 250 | 125 | 4-φ12 | 80 | 255 | 160 | 360 | 250 | 219 | 0 | 50 |
| 50KQW10-27-1.5/2 | 520 | 379 | 250 | 125 | 4-φ12 | 80 | 255 | 160 | 360 | 250 | 219 | 0 | 50 |
| 50KQW12.5-32-2.2/2 | 550 | 379 | 250 | 125 | 4-φ12 | 80 | 280 | 160 | 385 | 250 | 219 | 0 | 50 |
| 50KQW10-36-3/2 | 613 | 502 | 320 | 160 | 4-φ15 | 100 | 325 | 220 | 425 | 320 | 277 | 12.5 | 50 |
| 50KQW12-44-4/2 | 648 | 502 | 320 | 160 | 4-φ15 | 100 | 335 | 220 | 435 | 320 | 277 | 12.5 | 50 |
| 50KQW12.5-50-5.5/2 | 678 | 502 | 320 | 160 | 4-φ15 | 100 | 370 | 220 | 470 | 320 | 277 | 12.5 | 50 |

性能曲线 CHARACTERISTIC CURVE

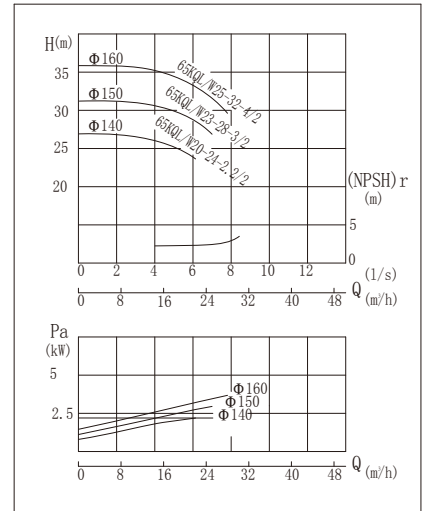
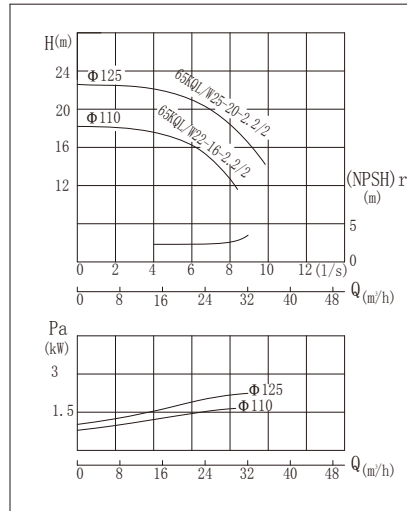
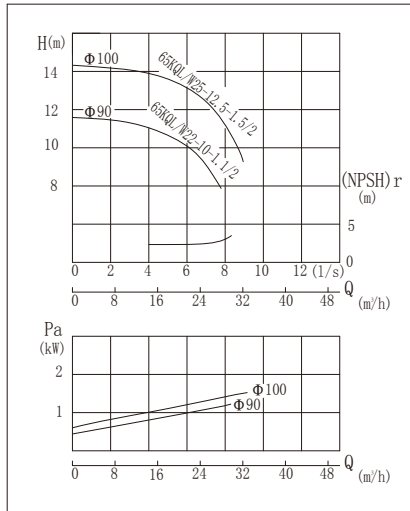

尺寸图 DIMENSION FIGURE

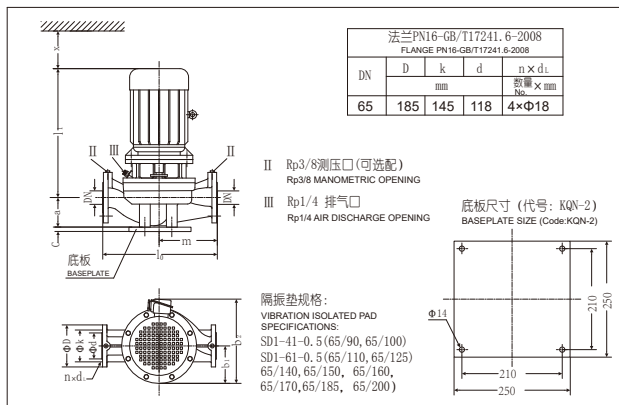

KQL尺寸表 DIMENSION TABLE

| 型号 TYPE | DN | l ₀ | m | a | c | l ₁ | b ₁ | b ₂ | x |
|--------------------|----|----------------|-----|-----|----|----------------|----------------|----------------|-----|
| | | mm | | | | | | | |
| 65KQL22-10-1.1/2 | 65 | 420 | 210 | 130 | 30 | 395 | 120 | 265 | 105 |
| 65KQL25-12.5-1.5/2 | 65 | 420 | 210 | 130 | 30 | 440 | 120 | 280 | 105 |
| 65KQL22-16-2.2/2 | 65 | 420 | 210 | 130 | 30 | 470 | 120 | 280 | 105 |
| 65KQL25-20-2.2/2 | 65 | 420 | 210 | 130 | 30 | 470 | 120 | 280 | 105 |
| 65KQL20-24-2.2/2 | 65 | 420 | 210 | 130 | 30 | 470 | 120 | 280 | 105 |
| 65KQL23-28-3/2 | 65 | 420 | 210 | 130 | 30 | 505 | 125 | 295 | 105 |
| 65KQL25-32-4/2 | 65 | 420 | 210 | 130 | 30 | 540 | 125 | 315 | 105 |
| 65KQL22-38-5.5/2 | 65 | 400 | 200 | 150 | 30 | 577 | 185 | 400 | 105 |
| 65KQL23-44-5.5/2 | 65 | 400 | 200 | 150 | 30 | 577 | 185 | 400 | 105 |
| 65KQL25-50-7.5/2 | 65 | 400 | 200 | 150 | 30 | 577 | 185 | 400 | 105 |

性能曲线CHARACTERISTIC CURVE

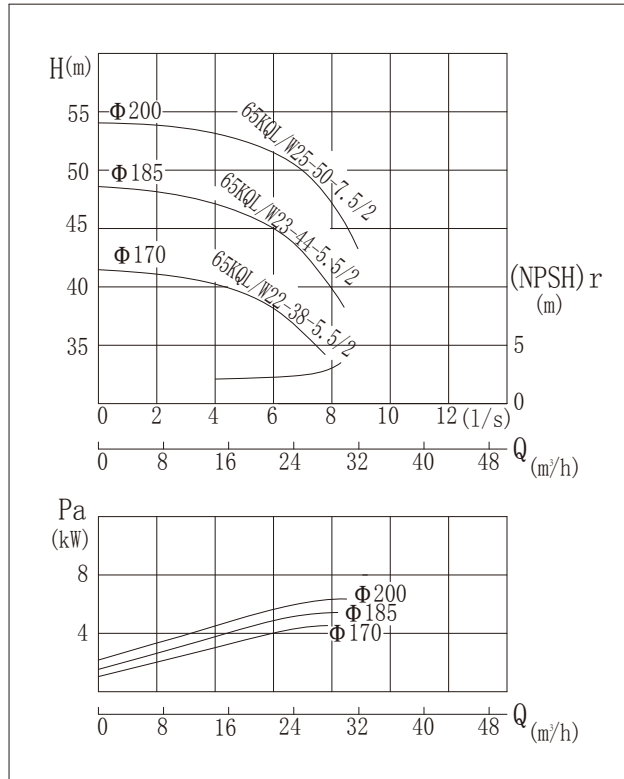

参数表PERFORMANCE DATA

| 型号 TYPE | 流量 Capacity | | 扬程 Head (m) | 转速 Speed (r/min) | 效率 Efficiency (%) | 电机 功率 Power (kW) | 必需汽蚀 余量 (NPSH)r (m) | 重量 Weight (kg) |
|----------------------|----------------|-------|-------------------|------------------------|-------------------------|---------------------------|------------------------------|----------------------|
| | (m³/h) | (l/s) | | | | | | |
| 65KQL/W22-10-1.1/2 | 15.6 | 4.3 | 11 | 2960 | 65 | 1.1 | 2.5 | 31 |
| | 22.3 | 6.19 | 10 | | | | | |
| | 27 | 7.5 | 8.4 | | | | | |
| 65KQL/W25-12.5-1.5/2 | 17.5 | 4.86 | 13.7 | 2960 | 65.5 | 1.5 | 2.5 | 53 |
| | 25 | 6.94 | 12.5 | | | | | |
| | 30 | 8.33 | 10.5 | | | | | |
| 65KQL/W22-16-2.2/2 | 15.6 | 4.3 | 17 | 2960 | 65 | 2.2 | 2.5 | 58 |
| | 22.3 | 6.19 | 16 | | | | | |
| | 27 | 7.5 | 14.4 | | | | | |
| 65KQL/W25-20-2.2/2 | 17.5 | 4.86 | 21 | 2960 | 71.4 | 2.2 | 2.5 | 64 |
| | 25 | 6.94 | 20 | | | | | |
| | 27.5 | 7.64 | 18.5 | | | | | |
| 65KQL/W20-24-2.2/2 | 14 | 3.89 | 25.2 | 2960 | 65 | 2.2 | 2.5 | 64 |
| | 20 | 6 | 24 | | | | | |
| | 22 | 6.11 | 23.2 | | | | | |
| 65KQL/W23-28-3/2 | 16.1 | 4.47 | 29.4 | 2960 | 66 | 3 | 2.5 | 75 |
| | 23 | 6.5 | 28 | | | | | |
| | 25.3 | 7.03 | 26.8 | | | | | |
| 65KQL/W25-32-4/2 | 17.5 | 4.86 | 34.3 | 2960 | 66.7 | 4 | 2.5 | 73 |
| | 25 | 6.94 | 32 | | | | | |
| | 30 | 8.33 | 28.5 | | | | | |
| 65KQL/W22-38-5.5/2 | 15.2 | 4.22 | 40 | 2960 | 57 | 5.5 | 2.5 | 124 |
| | 21.8 | 6.06 | 38 | | | | | |
| | 26.2 | 7.27 | 34.5 | | | | | |
| 65KQL/W23-44-5.5/2 | 16.4 | 4.55 | 46.2 | 2960 | 58 | 5.5 | 2.5 | 124 |
| | 23.4 | 6.5 | 44 | | | | | |
| | 25.7 | 7.15 | 39.6 | | | | | |
| 65KQL/W25-50-7.5/2 | 17.5 | 4.86 | 52.7 | 2960 | 59 | 7.5 | 2.5 | 124 |
| | 25 | 6.94 | 50 | | | | | |
| | 30 | 8.33 | 45.5 | | | | | |

尺寸图DIMENSION FIGURE

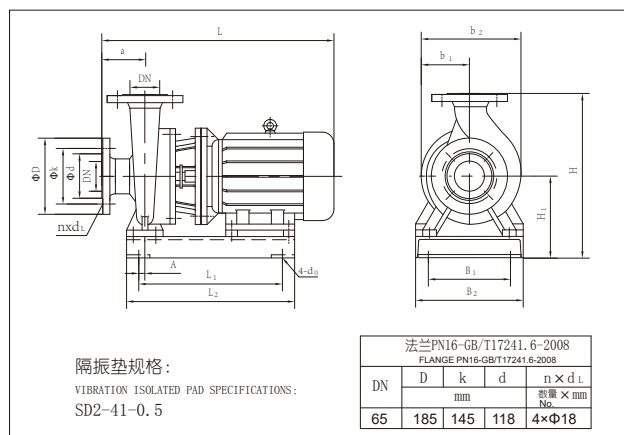

KQW尺寸表DIMENSION TABLE

| 型号 TYPE | 外形尺寸 Figure dimensions | | | | 安装尺寸 Installing dimensions | | | | | | | | DN |
|--------------------|---------------------------|-----|----------------|----------------|-------------------------------|-----|----------------|----------------|----------------|----------------|----------------|------|----|
| | L | H | b ₂ | b ₁ | 4-d _a | a | L ₁ | B ₁ | L ₂ | B ₂ | H ₁ | A | |
| 65KQW22-10-1.1/2 | 475 | 409 | 250 | 125 | 4-Φ12 | 80 | 245 | 160 | 345 | 250 | 219 | 0 | 65 |
| 65KQW25-12.5-1.5/2 | 520 | 409 | 250 | 125 | 4-Φ12 | 80 | 255 | 160 | 360 | 250 | 219 | 0 | 65 |
| 65KQW22-16-2.2/2 | 550 | 409 | 250 | 125 | 4-Φ12 | 80 | 280 | 160 | 385 | 250 | 219 | 0 | 65 |
| 65KQW25-20-2.2/2 | 550 | 409 | 250 | 125 | 4-Φ12 | 80 | 280 | 160 | 385 | 250 | 219 | 0 | 65 |
| 65KQW20-24-2.2/2 | 550 | 409 | 250 | 125 | 4-Φ12 | 80 | 280 | 160 | 385 | 250 | 219 | 0 | 65 |
| 65KQW23-28-3/2 | 585 | 409 | 250 | 125 | 4-Φ12 | 80 | 300 | 160 | 405 | 250 | 219 | 0 | 65 |
| 65KQW25-32-4/2 | 620 | 409 | 250 | 125 | 4-Φ12 | 80 | 310 | 160 | 410 | 250 | 219 | 0 | 65 |
| 65KQW22-38-5.5/2 | 677 | 507 | 320 | 160 | 4-Φ15 | 100 | 370 | 220 | 470 | 320 | 277 | 12.5 | 65 |
| 65KQW23-44-5.5/2 | 677 | 507 | 320 | 160 | 4-Φ15 | 100 | 370 | 220 | 470 | 320 | 277 | 12.5 | 65 |
| 65KQW25-50-7.5/2 | 677 | 507 | 320 | 160 | 4-Φ15 | 100 | 370 | 220 | 470 | 320 | 277 | 12.5 | 65 |

性能曲线 CHARACTERISTIC CURVE

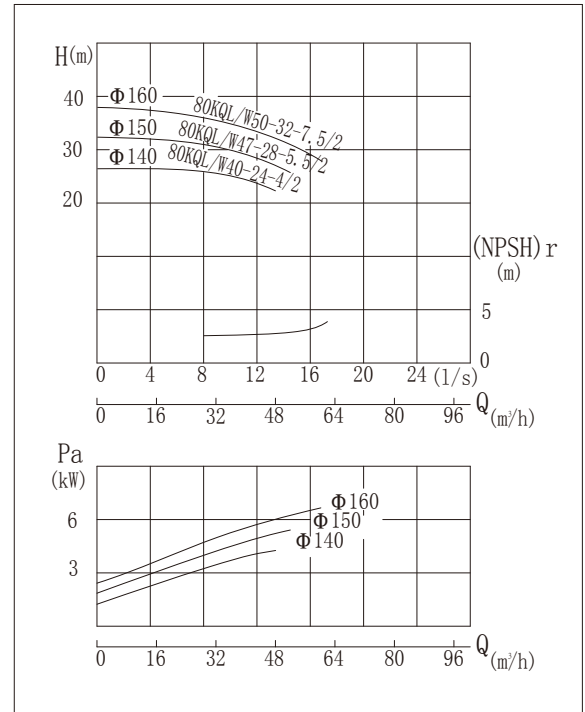
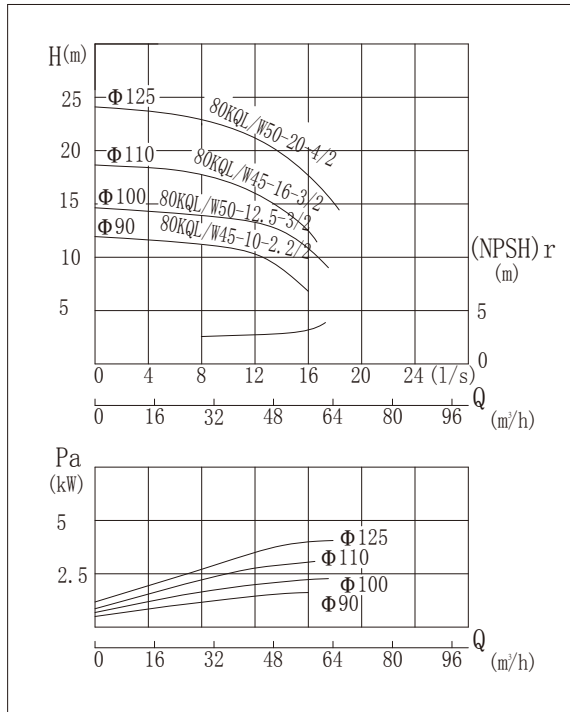

尺寸图 DIMENSION FIGURE

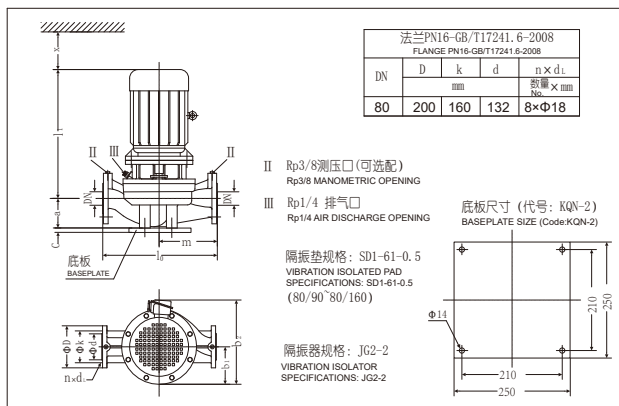

KQL尺寸表 DIMENSION TABLE

| 型号 TYPE | DN | l ₀ | m | a | c | l ₁ | b ₁ | b ₂ | x |
|------------------|----|----------------|-----|-----|----|----------------|----------------|----------------|-----|
| | | mm | | | | | | | |
| 80KQL45-10-2.2/2 | 80 | 490 | 245 | 145 | 30 | 470 | 120 | 290 | 110 |
| 80KQL50-12.5-3/2 | 80 | 490 | 245 | 145 | 30 | 505 | 125 | 295 | 110 |
| 80KQL45-16-3/2 | 80 | 490 | 245 | 145 | 30 | 505 | 125 | 295 | 110 |
| 80KQL50-20-4/2 | 80 | 490 | 245 | 145 | 30 | 540 | 125 | 315 | 110 |
| 80KQL40-24-4/2 | 80 | 490 | 245 | 145 | 30 | 540 | 125 | 315 | 110 |
| 80KQL47-28-5.5/2 | 80 | 490 | 245 | 145 | 30 | 560 | 185 | 400 | 110 |
| 80KQL50-32-7.5/2 | 80 | 490 | 245 | 145 | 30 | 560 | 185 | 400 | 110 |
| 80KQL35-34-5.5/2 | 80 | 490 | 245 | 145 | 30 | 560 | 185 | 400 | 110 |
| 80KQL44-38-7.5/2 | 80 | 540 | 270 | 155 | 30 | 577 | 185 | 400 | 120 |
| 80KQL47-44-11/2 | 80 | 540 | 270 | 155 | 30 | 705 | 225 | 485 | 120 |
| 80KQL50-50-15/2 | 80 | 540 | 270 | 155 | 30 | 705 | 225 | 485 | 120 |

性能曲线CHARACTERISTIC CURVE

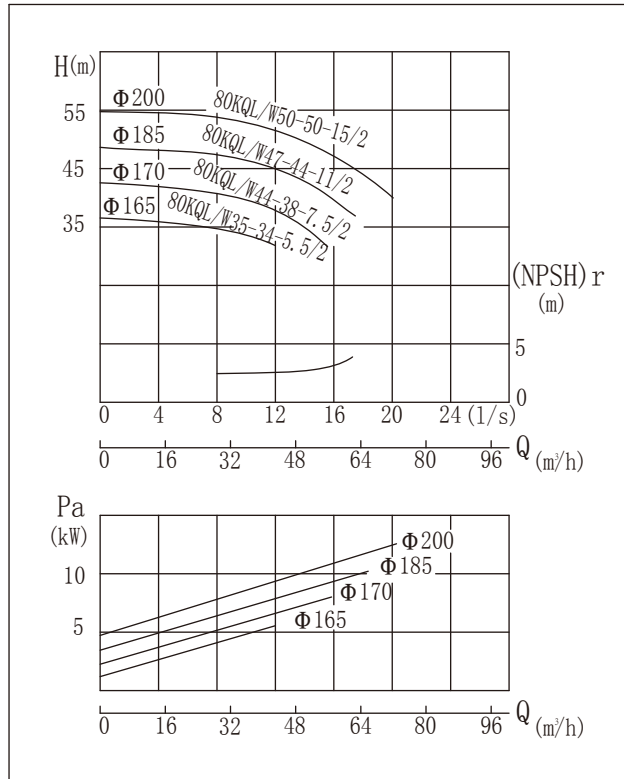

参数表PERFORMANCE DATA

| 型号 TYPE | 流量 Capacity | | 扬程 Head (m) | 转速 Speed (r/min) | 效率 Efficiency (%) | 电机 功率 Power (kW) | 必需汽蚀 余量 (NPSH) _r (m) | 重量 Weight (kg) |
|--------------------|----------------|-------|-------------------|------------------------|-------------------------|---------------------------|--|----------------------|
| | (m³/h) | (l/s) | | | | | | |
| 80KQL/W45-10-2.2/2 | 31.3 | 8.7 | 11.5 | 2960 | 72 | 2.2 | 3 | 63 |
| | 44.7 | 12.5 | 10 | | | | | |
| | 53.6 | 14.9 | 8 | | | | | |
| 80KQL/W50-12.5-3/2 | 35 | 9.72 | 14 | 2960 | 73 | 3 | 3 | 80 |
| | 50 | 13.9 | 12.5 | | | | | |
| | 60 | 16.7 | 10.1 | | | | | |
| 80KQL/W45-16-3/2 | 31.5 | 8.75 | 17.5 | 2960 | 76.4 | 3 | 3 | 79 |
| | 45 | 12.5 | 16 | | | | | |
| | 49.5 | 13.75 | 15 | | | | | |
| 80KQL/W50-20-4/2 | 35 | 9.72 | 21 | 2960 | 76.9 | 4 | 3 | 90 |
| | 50 | 13.9 | 20 | | | | | |
| | 55 | 15.28 | 18.3 | | | | | |
| 80KQL/W40-24-4/2 | 28 | 7.78 | 25.2 | 2960 | 75 | 4 | 3 | 90 |
| | 40 | 12 | 24 | | | | | |
| | 44 | 12.22 | 21.6 | | | | | |
| 80KQL/W47-28-5.5/2 | 32.69 | 9.08 | 30 | 2960 | 75 | 5.5 | 3 | 110 |
| | 46.7 | 13 | 28 | | | | | |
| | 51.37 | 14.27 | 25.8 | | | | | |
| 80KQL/W50-32-7.5/2 | 35 | 9.72 | 35 | 2960 | 75.4 | 7.5 | 3 | 113 |
| | 50 | 13.9 | 32 | | | | | |
| | 60 | 16.7 | 28 | | | | | |
| 80KQL/W35-34-5.5/2 | 24.5 | 6.81 | 35.7 | 2960 | 70 | 5.5 | 3 | 112 |
| | 35 | 9.72 | 34 | | | | | |
| | 38.5 | 10.69 | 32 | | | | | |
| 80KQL/W44-38-7.5/2 | 30.5 | 8.5 | 40.6 | 2960 | 70 | 7.5 | 3 | 115 |
| | 43.5 | 12.1 | 38 | | | | | |
| | 52 | 14.4 | 33.4 | | | | | |
| 80KQL/W47-44-11/2 | 32.8 | 9.1 | 47 | 2960 | 70 | 11 | 3 | 165 |
| | 47 | 13.1 | 44 | | | | | |
| | 56.4 | 15.7 | 40 | | | | | |
| 80KQL/W50-50-15/2 | 35 | 9.72 | 53.5 | 2960 | 71.4 | 15 | 3 | 185 |
| | 50 | 13.9 | 50 | | | | | |
| | 60 | 16.67 | 46 | | | | | |

尺寸图DIMENSION FIGURE

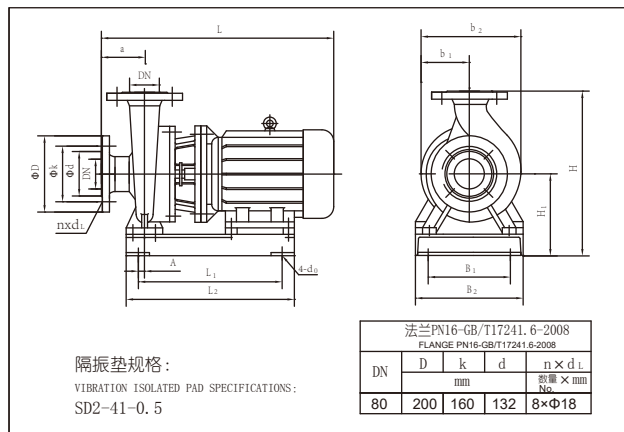

KQW尺寸表DIMENSION TABLE

| 型号 TYPE | 外形尺寸 Figure dimensions | | | | 安装尺寸 Installing dimensions | | | | | | | | DN |
|------------------|---------------------------|-----|----------------|----------------|-------------------------------|-----|----------------|----------------|----------------|----------------|----------------|------|----|
| | L | H | b ₂ | b ₁ | 4-φ _d | a | L ₁ | B ₁ | L ₂ | B ₂ | H ₁ | A | |
| 80KQW45-10-2.2/2 | 570 | 457 | 256 | 125 | 4-φ12 | 100 | 290 | 160 | 390 | 250 | 247 | 0 | 80 |
| 80KQW50-12.5-3/2 | 605 | 457 | 256 | 125 | 4-φ12 | 100 | 300 | 160 | 400 | 250 | 247 | 0 | 80 |
| 80KQW45-16-3/2 | 605 | 457 | 256 | 125 | 4-φ12 | 100 | 300 | 160 | 400 | 250 | 247 | 0 | 80 |
| 80KQW50-20-4/2 | 640 | 457 | 256 | 125 | 4-φ12 | 100 | 310 | 160 | 410 | 250 | 247 | 0 | 80 |
| 80KQW40-24-4/2 | 640 | 457 | 256 | 125 | 4-φ12 | 100 | 310 | 160 | 410 | 250 | 247 | 0 | 80 |
| 80KQW47-28-5.5/2 | 670 | 461 | 300 | 150 | 4-φ15 | 100 | 350 | 180 | 450 | 280 | 251 | 0 | 80 |
| 80KQW50-32-7.5/2 | 670 | 461 | 300 | 150 | 4-φ15 | 100 | 350 | 180 | 450 | 275 | 251 | 0 | 80 |
| 80KQW35-34-5.5/2 | 670 | 461 | 300 | 150 | 4-φ15 | 100 | 350 | 180 | 450 | 280 | 251 | 0 | 80 |
| 80KQW44-38-7.5/2 | 700 | 527 | 323 | 160 | 4-φ15 | 125 | 370 | 220 | 470 | 330 | 277 | 12.5 | 80 |
| 80KQW47-44-11/2 | 842 | 527 | 350 | 175 | 4-φ15 | 125 | 470 | 220 | 570 | 330 | 277 | 12.5 | 80 |
| 80KQW50-50-15/2 | 840 | 527 | 350 | 175 | 4-φ15 | 125 | 470 | 220 | 570 | 320 | 277 | 12.5 | 80 |

性能曲线 CHARACTERISTIC CURVE

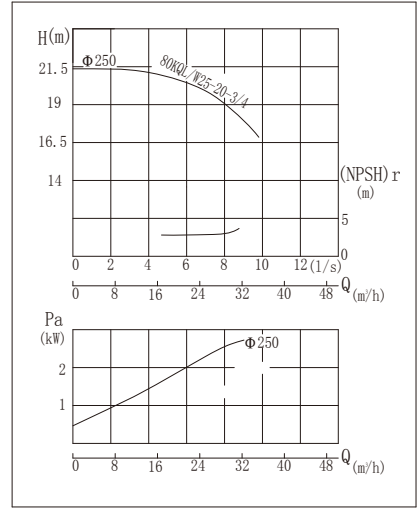
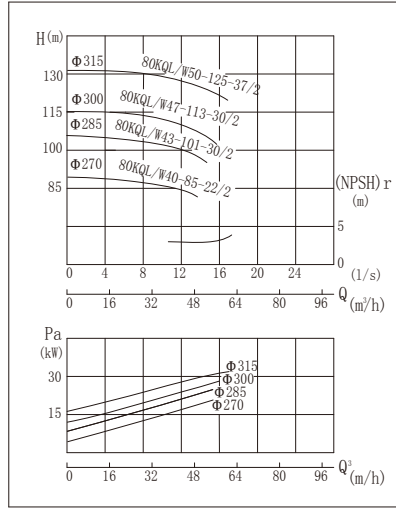
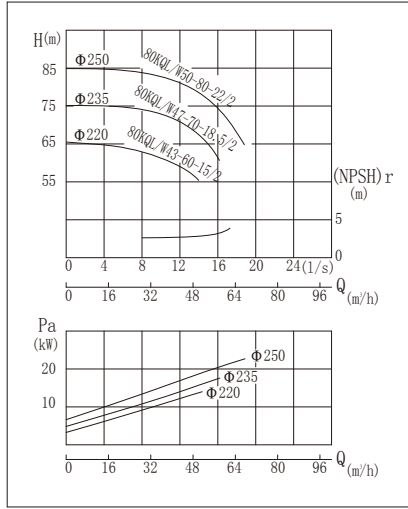

尺寸图 DIMENSION FIGURE

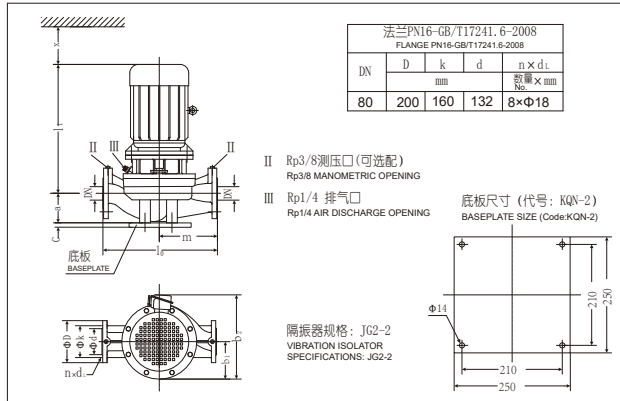

KQL尺寸表 DIMENSION TABLE

| 型号 TYPE | DN | l_0 | m | a | c | l_1 | b_1 | b_2 | x |
|-------------------|----|-------|-----|-----|-----|-------|-------|-------|-----|
| | | mm | | | | | | | |
| 80KQL43-60-15/2 | 80 | 540 | 270 | 155 | 30 | 705 | 225 | 485 | 120 |
| 80KQL47-70-18.5/2 | 80 | 540 | 270 | 155 | 30 | 735 | 225 | 485 | 120 |
| 80KQL50-80-22/2 | 80 | 540 | 270 | 155 | 30 | 775 | 250 | 530 | 120 |

尺寸图 DIMENSION FIGURE

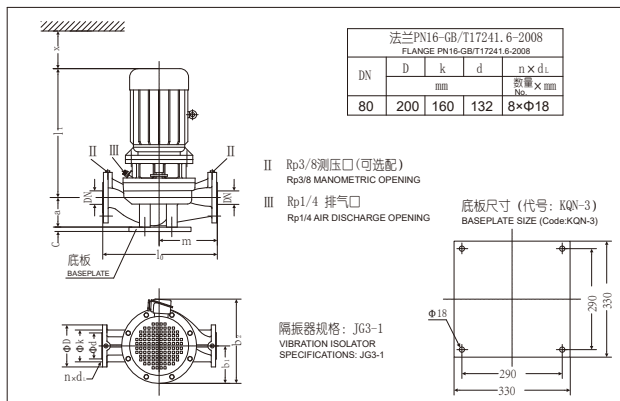

KQL尺寸表 DIMENSION TABLE

| 型号 TYPE | DN | l_0 | m | a | c | l_1 | b_1 | b_2 | x |
|------------------|----|-------|-----|-----|-----|-------|-------|-------|-----|
| | | mm | | | | | | | |
| 80KQL40-85-22/2 | 80 | 600 | 290 | 175 | 30 | 790 | 200 | 430 | 120 |
| 80KQL43-101-30/2 | 80 | 600 | 290 | 175 | 30 | 840 | 210 | 545 | 120 |
| 80KQL47-113-30/2 | 80 | 600 | 290 | 175 | 30 | 840 | 210 | 545 | 120 |
| 80KQL50-125-37/2 | 80 | 600 | 290 | 175 | 30 | 840 | 210 | 545 | 120 |
| 80KQL25-20-3/4 | 80 | 540 | 270 | 155 | 30 | 521 | 155 | 335 | 120 |
| 80KQL23-28-4/4 | 80 | 600 | 290 | 175 | 30 | 570 | 210 | 545 | 120 |
| 80KQL25-32-5.5/4 | 80 | 600 | 290 | 175 | 30 | 590 | 210 | 545 | 120 |

性能曲线CHARACTERISTIC CURVE

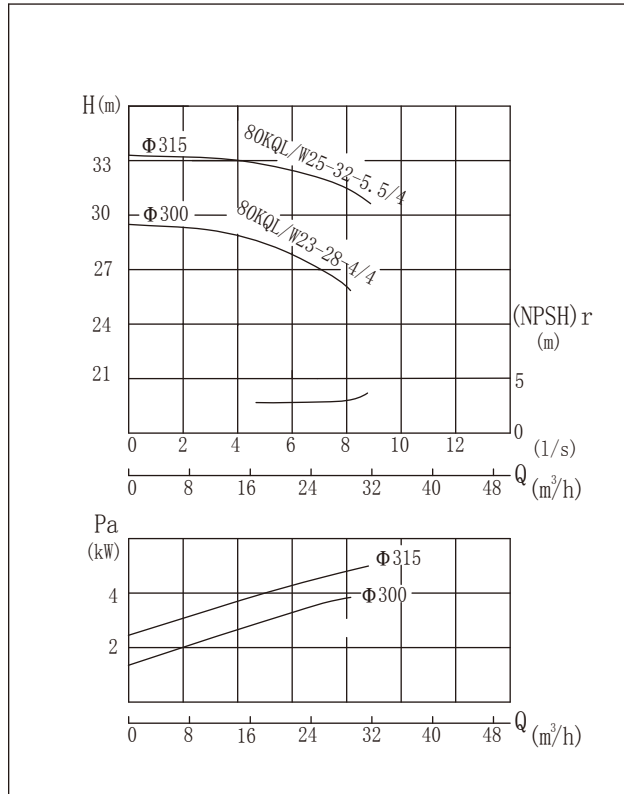

参数表PERFORMANCE DATA

| 型号 TYPE | 流量 Capacity | | 扬程 Head (m) | 转速 Speed (r/min) | 效率 Efficiency (%) | 电机 功率 Power (kW) | 必需汽蚀 余量 (NPSH)r (m) | 重量 Weight (kg) |
|---------------------|----------------|-------|-------------------|------------------------|-------------------------|---------------------------|------------------------------|----------------------|
| | (m³/h) | (l/s) | | | | | | |
| 80KQL/W43-60-15/2 | 30 | 8.3 | 62 | 2960 | 61 | 15 | 3 | 186 |
| | 43.3 | 12 | 60 | | | | | |
| | 52 | 14.4 | 54 | | | | | |
| 80KQL/W47-70-18.5/2 | 32.5 | 9 | 73 | 2960 | 62 | 18.5 | 3 | 205 |
| | 46.7 | 13 | 70 | | | | | |
| | 56 | 15.6 | 63 | | | | | |
| 80KQL/W50-80-22/2 | 35 | 9.72 | 83 | 2960 | 63 | 22 | 3 | 240 |
| | 50 | 13.9 | 80 | | | | | |
| | 60 | 16.7 | 72 | | | | | |
| 80KQL/W40-85-22/2 | 28 | 7.78 | 88 | 2960 | 54 | 22 | 3 | 249 |
| | 40 | 11.1 | 85 | | | | | |
| | 48 | 13.3 | 78 | | | | | |
| 80KQL/W43-101-30/2 | 30 | 8.3 | 105 | 2960 | 55 | 30 | 3 | 420 |
| | 43.3 | 12 | 101 | | | | | |
| | 52 | 14.4 | 94 | | | | | |
| 80KQL/W47-113-30/2 | 32.5 | 9 | 117 | 2960 | 56 | 30 | 3 | 420 |
| | 46.7 | 13 | 113 | | | | | |
| | 56 | 15.6 | 106 | | | | | |
| 80KQL/W50-125-37/2 | 35 | 9.72 | 129 | 2960 | 57 | 37 | 3 | 450 |
| | 50 | 13.9 | 125 | | | | | |
| | 60 | 16.7 | 118 | | | | | |
| 80KQL/W25-20-3/4 | 15 | 4.17 | 21 | 1480 | 59 | 3 | 2.8 | 145 |
| | 25 | 6.94 | 20 | | | | | |
| | 30 | 8.33 | 18.3 | | | | | |
| 80KQL/W23-28-4/4 | 14 | 3.89 | 28.3 | 1480 | 52 | 4 | 2.8 | 181 |
| | 23 | 6.39 | 27.9 | | | | | |
| | 28 | 7.78 | 25.3 | | | | | |
| 80KQL/W25-32-5.5/4 | 15 | 4.17 | 33 | 1480 | 52.6 | 5.5 | 2.8 | 188 |
| | 25 | 6.94 | 32 | | | | | |
| | 30 | 8.33 | 30 | | | | | |

尺寸图DIMENSION FIGURE

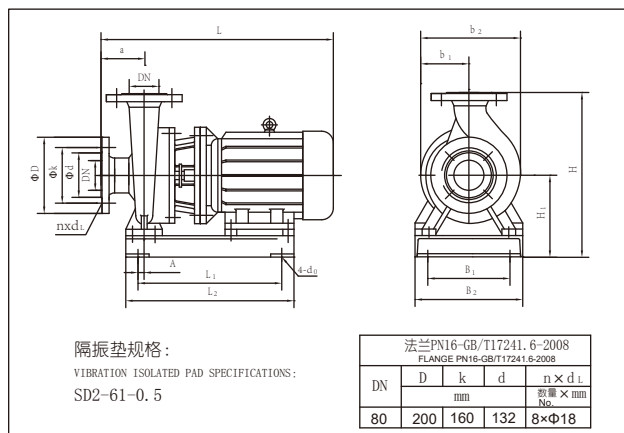

KQW尺寸表DIMENSION TABLE

| 型号 TYPE | 外形尺寸 Figure dimensions | | | | 安装尺寸 Installing dimensions | | | | | | | | DN |
|-------------------|---------------------------|-----|----------------|----------------|-------------------------------|-----|----------------|----------------|----------------|----------------|----------------|------|----|
| | L | H | b ₂ | b ₁ | 4-φ _d | a | L ₁ | B ₁ | L ₂ | B ₂ | H ₁ | A | |
| 80KQW43-60-15/2 | 840 | 527 | 350 | 175 | 4-φ15 | 125 | 470 | 220 | 570 | 330 | 277 | 12.5 | 80 |
| 80KQW47-70-18.5/2 | 870 | 527 | 350 | 175 | 4-φ15 | 125 | 510 | 220 | 610 | 330 | 277 | 12.5 | 80 |
| 80KQW50-80-22/2 | 910 | 535 | 380 | 190 | 4-φ15 | 125 | 515 | 260 | 615 | 370 | 285 | 12.5 | 80 |
| 80KQW40-85-22/2 | 925 | 620 | 393 | 190 | 4-φ15 | 125 | 520 | 260 | 620 | 360 | 330 | 12.5 | 80 |
| 80KQW43-101-30/2 | 975 | 619 | 420 | 210 | 4-φ15 | 125 | 610 | 300 | 710 | 400 | 329 | 12.5 | 80 |
| 80KQW47-113-30/2 | 975 | 619 | 420 | 210 | 4-φ15 | 125 | 610 | 300 | 710 | 400 | 329 | 12.5 | 80 |
| 80KQW50-125-37/2 | 975 | 619 | 420 | 210 | 4-φ15 | 125 | 610 | 300 | 710 | 400 | 329 | 12.5 | 80 |
| 80KQW25-20-3/4 | 645 | 527 | 323 | 160 | 4-φ15 | 125 | 315 | 220 | 425 | 320 | 277 | 10 | 80 |
| 80KQW23-28-4/4 | 675 | 620 | 392 | 189 | 4-φ15 | 125 | 315 | 280 | 440 | 360 | 330 | 10 | 80 |
| 80KQW25-32-5.5/4 | 705 | 620 | 392 | 189 | 4-φ15 | 125 | 395 | 280 | 470 | 360 | 330 | 20 | 80 |

性能曲线 CHARACTERISTIC CURVE

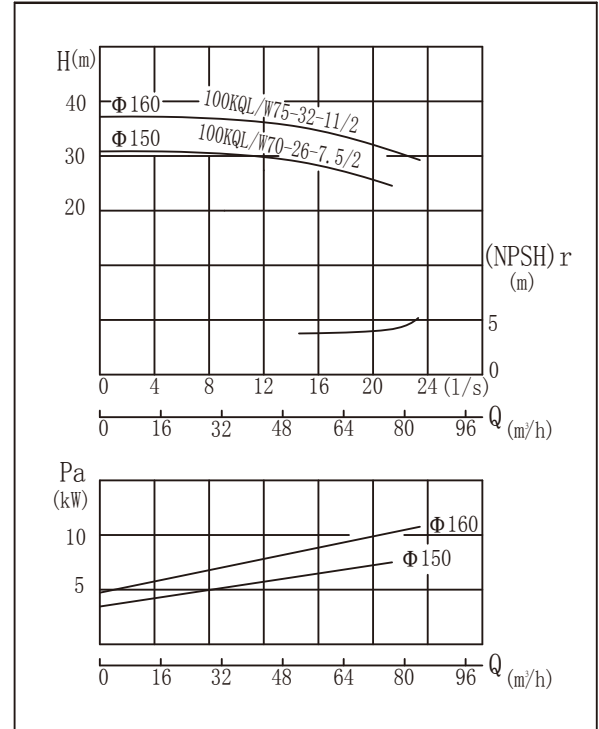
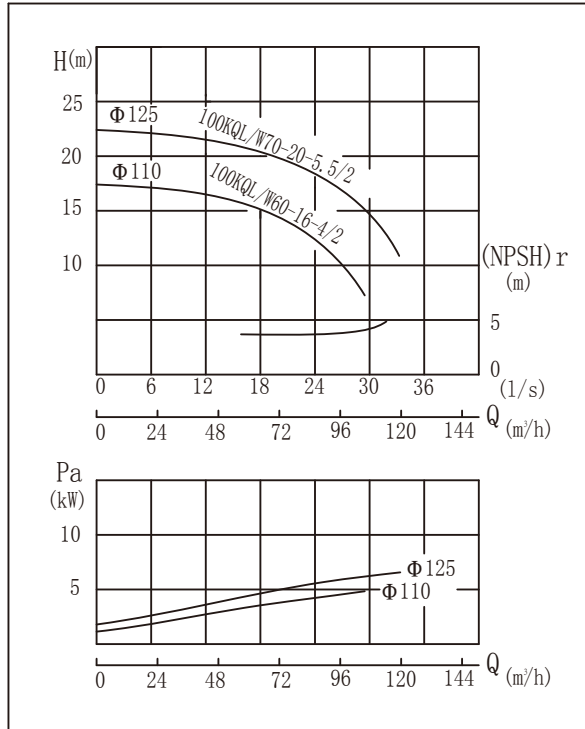

尺寸图 DIMENSION FIGURE

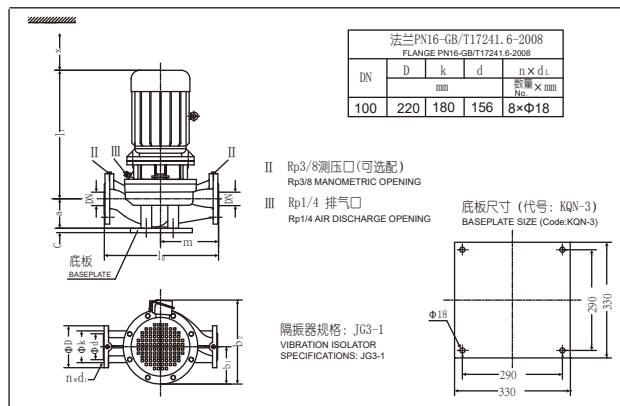

KQL尺寸表 DIMENSION TABLE

| 型号 TYPE | DN | l_0 | m | a | c | l_1 | b_1 | b_2 | x |
|--------------------|-----|-------|-----|-----|-----|-------|-------|-------|-----|
| | | mm | | | | | | | |
| 100KQL60-16-4/2 | 100 | 580 | 280 | 180 | 30 | 560 | 125 | 315 | 130 |
| 100KQL70-20-5.5/2 | 100 | 580 | 280 | 180 | 30 | 580 | 185 | 400 | 130 |
| 100KQL70-26-7.5/2 | 100 | 580 | 280 | 180 | 30 | 580 | 185 | 400 | 130 |
| 100KQL75-32-11/2 | 100 | 580 | 280 | 180 | 30 | 710 | 225 | 485 | 130 |
| 100KQL68-38-11/2 | 100 | 630 | 310 | 180 | 30 | 720 | 225 | 485 | 130 |
| 100KQL72-44-15/2 | 100 | 630 | 310 | 180 | 30 | 720 | 225 | 485 | 130 |
| 100KQL75-50-18.5/2 | 100 | 630 | 310 | 180 | 30 | 750 | 225 | 485 | 130 |

性能曲线CHARACTERISTIC CURVE

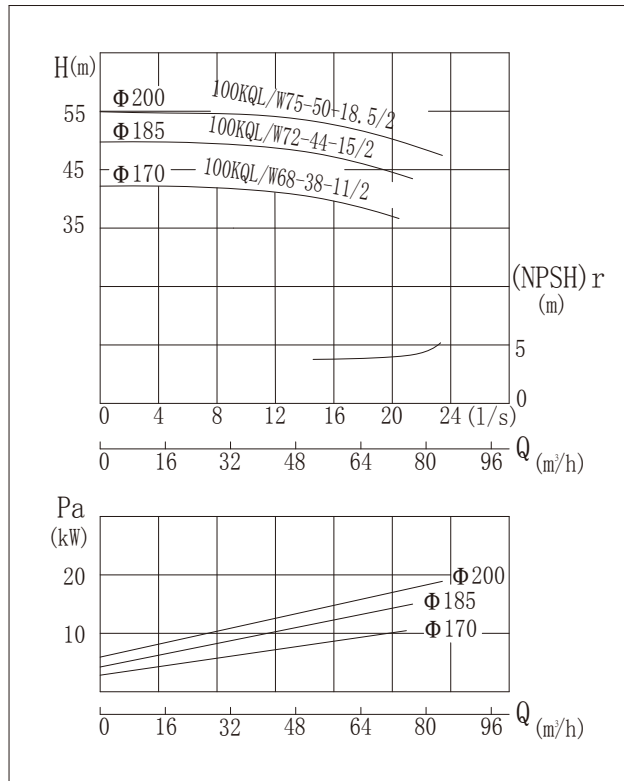

参数表PERFORMANCE DATA

| 型号 TYPE | 流量 Capacity | | 扬程 Head (m) | 转速 Speed (r/min) | 效率 Efficiency (%) | 电机 功率 Power (kW) | 必需汽蚀 余量 (NPSH)r (m) | 重量 Weight (kg) |
|----------------------|----------------|-------|-------------------|------------------------|-------------------------|---------------------------|------------------------------|----------------------|
| | 3 (m³/h) | (l/s) | | | | | | |
| 100KQL/W60-16-4/2 | 42 | 11.7 | 17.5 | 2960 | 77 | 4 | 4.5 | 91 |
| | 60 | 16.7 | 16 | | | | | |
| | 66 | 18.3 | 14.8 | | | | | |
| 100KQL/W70-20-5.5/2 | 49 | 13.6 | 22 | 2960 | 78 | 5.5 | 4.5 | 115 |
| | 70 | 19.4 | 20 | | | | | |
| | 77 | 21.4 | 18.5 | | | | | |
| 100KQL/W70-26-7.5/2 | 49 | 13.6 | 27.3 | 2960 | 77 | 7.5 | 4.5 | 132 |
| | 70 | 19.4 | 26 | | | | | |
| | 77 | 21.4 | 24.3 | | | | | |
| 100KQL/W75-32-11/2 | 52.5 | 14.6 | 34.5 | 2960 | 78 | 11 | 4.5 | 178 |
| | 75 | 20.8 | 32 | | | | | |
| | 82.5 | 22.9 | 29.3 | | | | | |
| 100KQL/W68-38-11/2 | 47.6 | 13.2 | 41 | 2960 | 74 | 11 | 4 | 179 |
| | 68 | 18.9 | 38 | | | | | |
| | 74.8 | 20.8 | 34.2 | | | | | |
| 100KQL/W72-44-15/2 | 50.4 | 14.0 | 48.5 | 2960 | 75 | 15 | 4 | 189 |
| | 72 | 20.0 | 44 | | | | | |
| | 79.2 | 22.0 | 41 | | | | | |
| 100KQL/W75-50-18.5/2 | 52.5 | 14.6 | 53 | 2960 | 76 | 18.5 | 4 | 218 |
| | 75 | 20.8 | 50 | | | | | |
| | 82.5 | 22.9 | 46 | | | | | |

尺寸图DIMENSION FIGURE

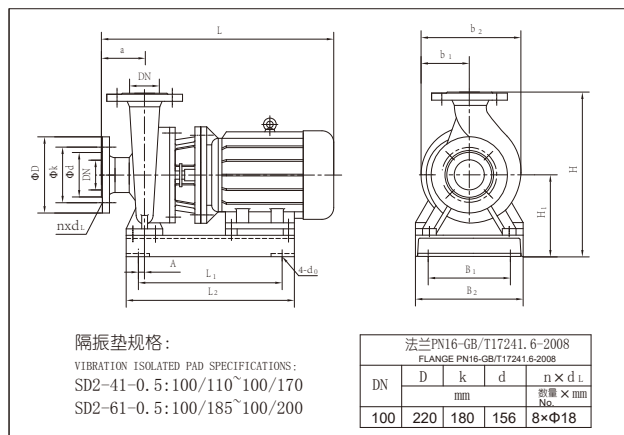

KQW尺寸表DIMENSION TABLE

| 型号 TYPE | 外形尺寸 Figure dimensions | | | | 安装尺寸 Installing dimensions | | | | | | | | DN |
|--------------------|---------------------------|-----|----------------|----------------|-------------------------------|-----|----------------|----------------|----------------|----------------|----------------|------|-----|
| | L | H | b ₂ | b ₁ | 4-φ ₀ | a | L ₁ | B ₁ | L ₂ | B ₂ | H ₁ | A | |
| 100KQW60-16-4/2 | 670 | 516 | 302 | 150 | 4-φ15 | 100 | 345 | 180 | 445 | 280 | 251 | 12.5 | 100 |
| 100KQW70-20-5.5/2 | 690 | 516 | 302 | 150 | 4-φ15 | 100 | 375 | 180 | 475 | 280 | 251 | 12.5 | 100 |
| 100KQW70-26-7.5/2 | 690 | 516 | 302 | 150 | 4-φ15 | 100 | 375 | 180 | 475 | 280 | 251 | 12.5 | 100 |
| 100KQW75-32-11/2 | 820 | 517 | 350 | 175 | 4-φ15 | 100 | 475 | 220 | 575 | 320 | 252 | 12.5 | 100 |
| 100KQW68-38-11/2 | 845 | 595 | 368 | 180 | 4-φ15 | 125 | 475 | 260 | 575 | 360 | 305 | 12.5 | 100 |
| 100KQW72-44-15/2 | 845 | 595 | 368 | 180 | 4-φ15 | 125 | 475 | 260 | 575 | 360 | 305 | 12.5 | 100 |
| 100KQW75-50-18.5/2 | 875 | 595 | 368 | 180 | 4-φ15 | 125 | 515 | 260 | 615 | 360 | 305 | 12.5 | 100 |

性能曲线 CHARACTERISTIC CURVE

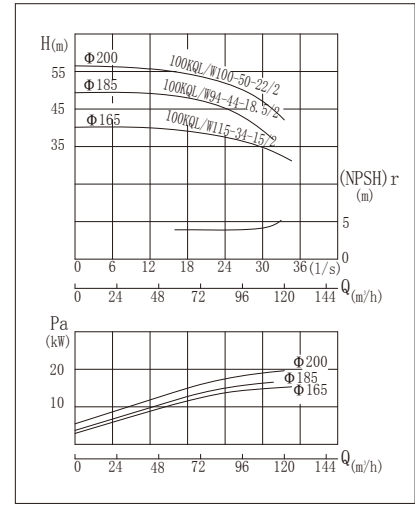
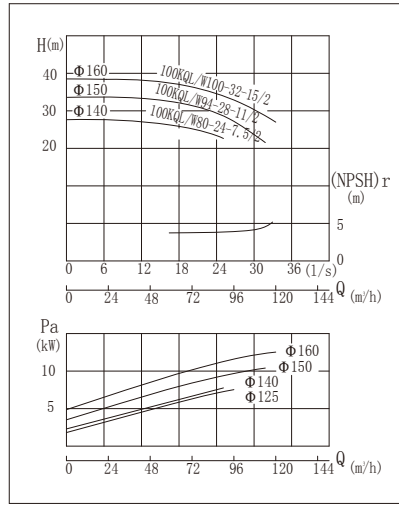
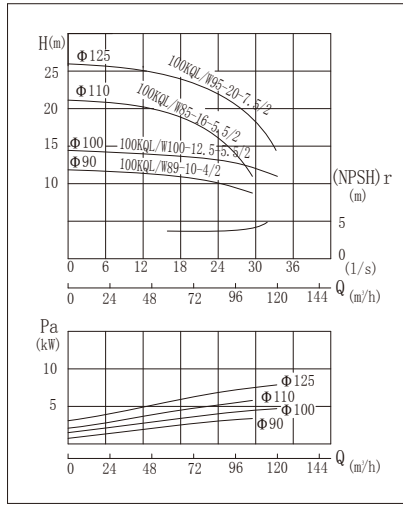

尺寸图 DIMENSION FIGURE

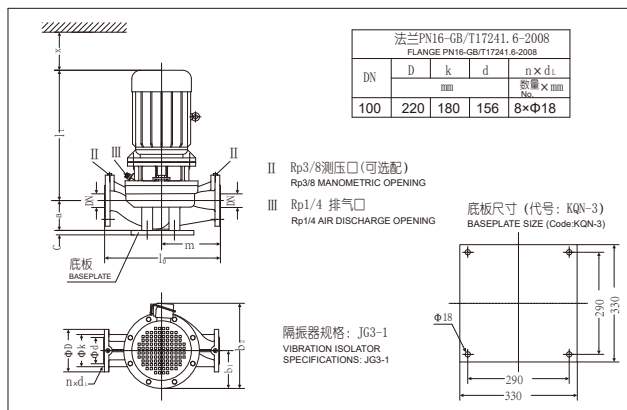

KQL尺寸表 DIMENSION TABLE

| 型号 TYPE | DN | l ₀ | m | a | c | l ₁ | b ₁ | b ₂ | x |
|----------------------|-----|----------------|-----|-----|----|----------------|----------------|----------------|-----|
| | | mm | | | | | | | |
| 100KQL89-10-4/2 | 100 | 580 | 280 | 180 | 30 | 560 | 125 | 360 | 130 |
| 100KQL100-12.5-5.5/2 | 100 | 580 | 280 | 180 | 30 | 580 | 185 | 400 | 130 |
| 100KQL85-16-5.5/2 | 100 | 580 | 280 | 180 | 30 | 580 | 185 | 400 | 130 |
| 100KQL95-20-7.5/2 | 100 | 580 | 280 | 180 | 30 | 580 | 185 | 400 | 130 |
| 100KQL80-24-7.5/2 | 100 | 580 | 280 | 180 | 30 | 580 | 185 | 400 | 130 |
| 100KQL94-28-11/2 | 100 | 580 | 280 | 180 | 30 | 710 | 225 | 485 | 130 |
| 100KQL100-32-15/2 | 100 | 580 | 280 | 180 | 30 | 710 | 225 | 485 | 130 |
| 100KQL115-34-15/2 | 100 | 580 | 280 | 180 | 30 | 710 | 225 | 485 | 130 |
| 100KQL94-44-18.5/2 | 100 | 630 | 310 | 180 | 30 | 750 | 225 | 485 | 130 |
| 100KQL100-50-22/2 | 100 | 630 | 310 | 180 | 30 | 790 | 250 | 530 | 130 |
| 100KQL87-60-30/2 | 100 | 630 | 310 | 180 | 30 | 840 | 270 | 575 | 130 |
| 100KQL94-70-30/2 | 100 | 630 | 310 | 180 | 30 | 840 | 270 | 575 | 130 |
| 100KQL100-80-37/2 | 100 | 630 | 310 | 180 | 30 | 840 | 270 | 575 | 130 |

性能曲线CHARACTERISTIC CURVE

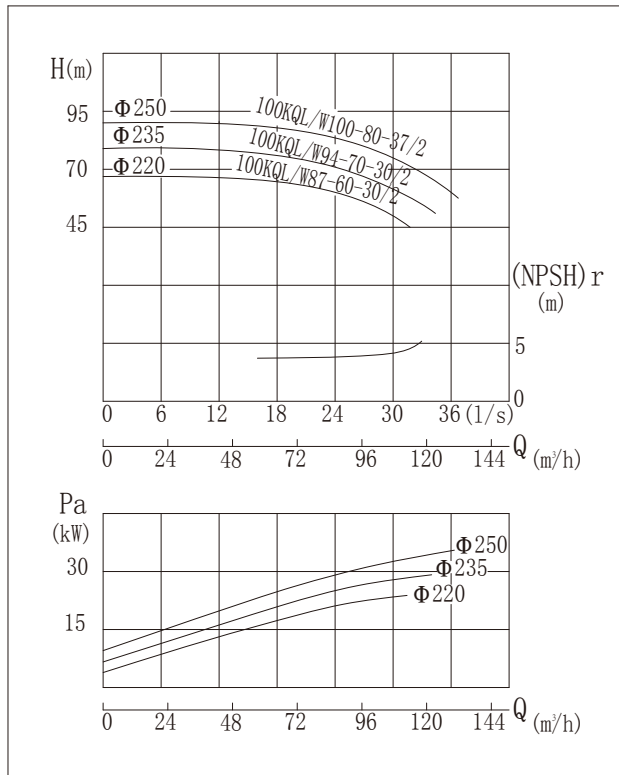

参数表PERFORMANCE DATA

| 型号 TYPE | 流量 Capacity | | 扬程 Head (m) | 转速 Speed (r/min) | 效率 Efficiency (%) | 电机 功率 Power (kW) | 必需汽蚀 余量 (NPSH) _r (m) | 重量 Weight (kg) |
|------------------------|----------------|-------|-------------------|------------------------|-------------------------|---------------------------|--|----------------------|
| | (m³/h) | (L/s) | | | | | | |
| 100KQL/W89-10-4/2 | 62.6 | 17.4 | 12 | 2960 | 77 | 4 | 4.5 | 94 |
| | 89 | 24.7 | 10 | | | | | |
| | 107 | 29.7 | 8.8 | | | | | |
| 100KQL/W100-12.5-5.5/2 | 70 | 19.4 | 13.6 | 2960 | 78 | 5.5 | 4.5 | 113 |
| | 100 | 27.8 | 12.5 | | | | | |
| | 120 | 33.3 | 8 | | | | | |
| 100KQL/W85-16-5.5/2 | 59.5 | 16.5 | 16.8 | 2960 | 79 | 5.5 | 4.5 | 115 |
| | 85 | 23.6 | 16 | | | | | |
| | 93.5 | 26.0 | 14.4 | | | | | |
| 100KQL/W95-20-7.5/2 | 66.5 | 18.5 | 22.8 | 2960 | 80 | 7.5 | 4.5 | 132 |
| | 95 | 26.4 | 20 | | | | | |
| | 104.5 | 29.0 | 18.5 | | | | | |
| 100KQL/W80-24-7.5/2 | 56 | 15.6 | 25.2 | 2960 | 79 | 7.5 | 4.5 | 135 |
| | 80 | 22.2 | 24 | | | | | |
| | 88 | 24.4 | 22.4 | | | | | |
| 100KQL/W94-28-11/2 | 65.4 | 18.2 | 32 | 2960 | 78 | 11 | 4.5 | 190 |
| | 93.5 | 26.0 | 28 | | | | | |
| | 112 | 31.1 | 23 | | | | | |
| 100KQL/W100-32-15/2 | 70 | 19.4 | 35 | 2960 | 79 | 15 | 4.5 | 195 |
| | 100 | 27.8 | 32 | | | | | |
| | 120 | 33.3 | 27 | | | | | |
| 100KQL/W115-34-15/2 | 80.5 | 22.4 | 38.5 | 2960 | 79 | 15 | 4.5 | 190 |
| | 115 | 31.9 | 34 | | | | | |
| | 126.5 | 35.1 | 32 | | | | | |
| 100KQL/W94-44-18.5/2 | 65.4 | 18.2 | 47.5 | 2960 | 78 | 18.5 | 4 | 218 |
| | 93.5 | 26.0 | 44 | | | | | |
| | 112 | 31.1 | 37 | | | | | |
| 100KQL/W100-50-22/2 | 70 | 19.4 | 54 | 2960 | 79 | 22 | 4 | 250 |
| | 100 | 27.8 | 50 | | | | | |
| | 120 | 33.3 | 42 | | | | | |
| 100KQL/W87-60-30/2 | 61 | 16.9 | 65 | 2960 | 73 | 30 | 4 | 346 |
| | 87 | 24.2 | 60 | | | | | |
| | 104 | 28.9 | 50 | | | | | |
| 100KQL/W94-70-30/2 | 65.4 | 18.2 | 76 | 2960 | 74 | 30 | 4 | 347 |
| | 93.5 | 26.0 | 70 | | | | | |
| | 112 | 31.1 | 59 | | | | | |
| 100KQL/W100-80-37/2 | 70 | 19.4 | 87 | 2960 | 75 | 37 | 4 | 370 |
| | 100 | 27.8 | 80 | | | | | |
| | 120 | 33.3 | 68 | | | | | |

尺寸图DIMENSION FIGURE

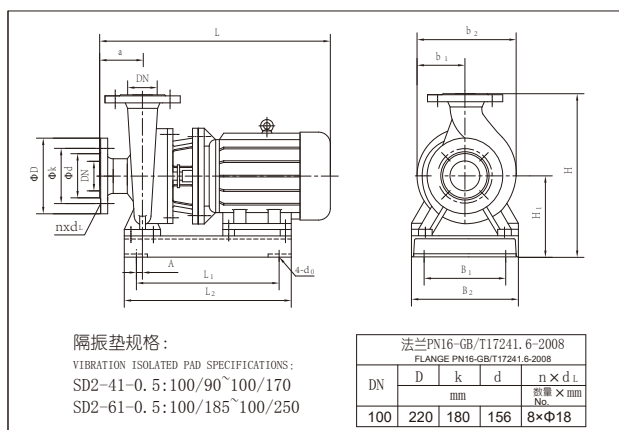

KQW尺寸表DIMENSION TABLE

| 型号 TYPE | 外形尺寸 Figure dimensions | | | | 安装尺寸 Installing dimensions | | | | | | DN | | |
|----------------------|---------------------------|-----|----------------|----------------|-------------------------------|-----|----------------|----------------|----------------|----------------|-----|----------------|-----|
| | L | H | b ₂ | b ₁ | 4-φ ₀ | a | L ₁ | B ₁ | L ₂ | B ₂ | | H ₁ | A |
| 100KQW89-10-4/2 | 650 | 516 | 302 | 150 | 4-φ15 | 100 | 345 | 180 | 445 | 280 | 251 | 12.5 | 100 |
| 100KQW100-12.5-5.5/2 | 690 | 516 | 302 | 150 | 4-φ15 | 100 | 375 | 180 | 475 | 280 | 251 | 12.5 | 100 |
| 100KQW85-16-5.5/2 | 690 | 516 | 302 | 150 | 4-φ15 | 100 | 375 | 180 | 475 | 280 | 251 | 12.5 | 100 |
| 100KQW95-20-7.5/2 | 690 | 516 | 302 | 150 | 4-φ15 | 100 | 375 | 180 | 475 | 280 | 251 | 12.5 | 100 |
| 100KQW80-24-7.5/2 | 690 | 516 | 302 | 150 | 4-φ15 | 100 | 375 | 180 | 475 | 280 | 251 | 12.5 | 100 |
| 100KQW94-28-11/2 | 820 | 517 | 350 | 175 | 4-φ15 | 100 | 475 | 220 | 575 | 320 | 252 | 12.5 | 100 |
| 100KQW100-32-15/2 | 820 | 517 | 350 | 175 | 4-φ15 | 100 | 475 | 220 | 575 | 320 | 252 | 12.5 | 100 |
| 100KQW115-34-15/2 | 820 | 517 | 350 | 175 | 4-φ15 | 100 | 475 | 220 | 575 | 320 | 252 | 12.5 | 100 |
| 100KQW94-44-18.5/2 | 875 | 595 | 368 | 180 | 4-φ15 | 125 | 515 | 260 | 615 | 360 | 305 | 12.5 | 100 |
| 100KQW100-50-22/2 | 915 | 595 | 380 | 190 | 4-φ15 | 125 | 520 | 260 | 620 | 360 | 305 | 12.5 | 100 |
| 100KQW87-60-30/2 | 975 | 594 | 420 | 210 | 4-φ15 | 125 | 610 | 300 | 710 | 400 | 304 | 12.5 | 100 |
| 100KQW94-70-30/2 | 975 | 594 | 420 | 210 | 4-φ15 | 125 | 610 | 300 | 710 | 400 | 304 | 12.5 | 100 |
| 100KQW100-80-37/2 | 975 | 594 | 420 | 210 | 4-φ15 | 125 | 610 | 300 | 710 | 400 | 304 | 12.5 | 100 |

性能曲线 CHARACTERISTIC CURVE

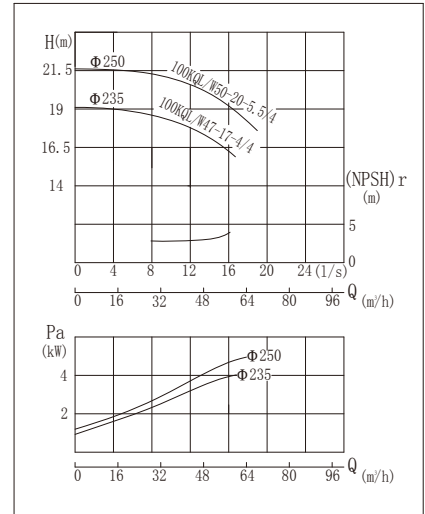
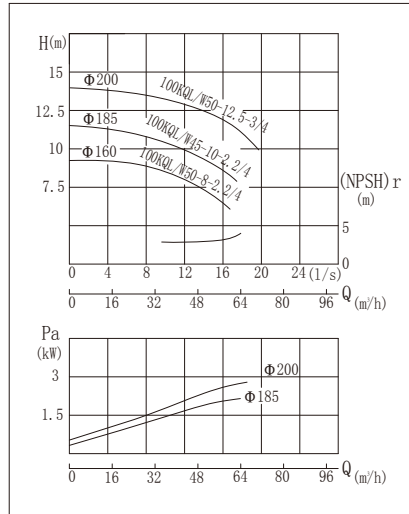
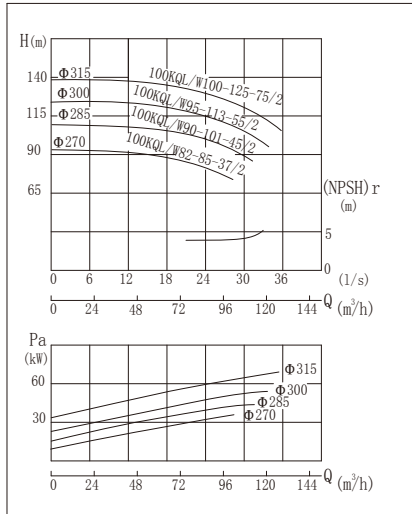

尺寸图 DIMENSION FIGURE

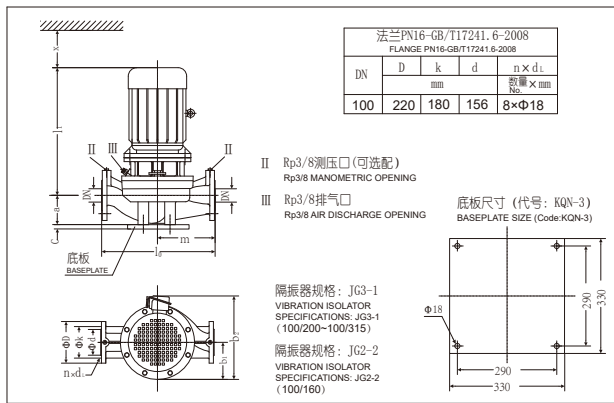

KQL尺寸表 DIMENSION TABLE

| 型号 TYPE | DN | l_0 | m | a | c | l_1 | b_1 | b_2 | x |
|--------------------|-----|-------|-----|-----|-----|-------|-------|-------|-----|
| | | mm | | | | | | | |
| 100KQL82-85-37/2 | 100 | 640 | 315 | 175 | 30 | 860 | 210 | 525 | 130 |
| 100KQL90-101-45/2 | 100 | 640 | 315 | 175 | 30 | 895 | 240 | 585 | 130 |
| 100KQL95-113-55/2 | 100 | 640 | 315 | 175 | 30 | 955 | 275 | 660 | 130 |
| 100KQL100-125-75/2 | 100 | 640 | 315 | 175 | 30 | 1035 | 295 | 705 | 130 |
| 100KQL50-8-2.2/4 | 100 | 580 | 280 | 180 | 30 | 525 | 130 | 310 | 130 |
| 100KQL45-10-2.2/4 | 100 | 630 | 310 | 180 | 30 | 535 | 170 | 350 | 130 |
| 100KQL50-12.5-3/4 | 100 | 630 | 310 | 180 | 30 | 535 | 170 | 360 | 130 |
| 100KQL47-17-4/4 | 100 | 630 | 310 | 180 | 30 | 570 | 170 | 360 | 130 |
| 100KQL50-20-5.5/4 | 100 | 630 | 310 | 180 | 30 | 590 | 170 | 380 | 130 |
| 100KQL47-28-7.5/4 | 100 | 640 | 315 | 175 | 30 | 659 | 205 | 415 | 130 |
| 100KQL50-32-11/4 | 100 | 640 | 315 | 175 | 30 | 739 | 205 | 470 | 130 |

性能曲线CHARACTERISTIC CURVE

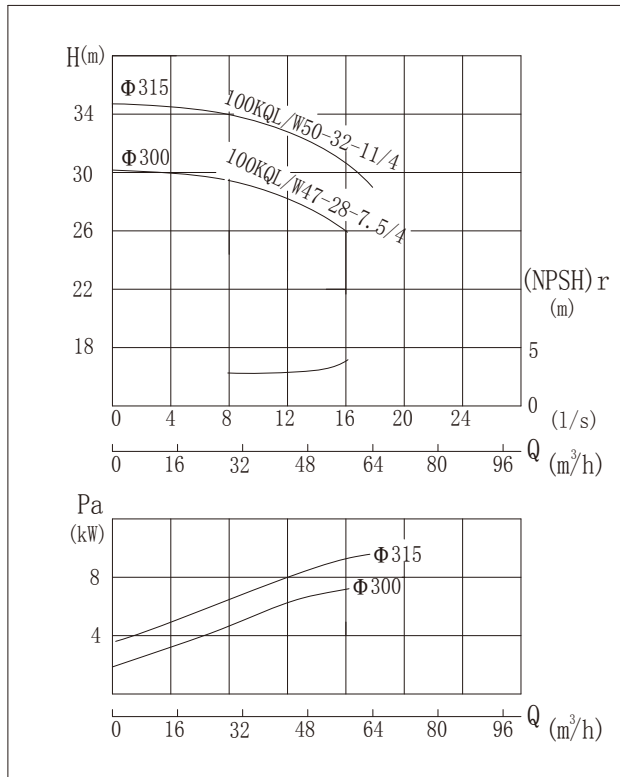

参数表PERFORMANCE DATA

| 型号 TYPE | 流量 Capacity | | 扬程 Head (m) | 转速 Speed (r/min) | 效率 Efficiency (%) | 电机 功率 Power (kW) | 必需汽蚀 余量 (NPSH)r (m) | 重量 Weight (kg) |
|----------------------|----------------|-------|-------------------|------------------------|-------------------------|---------------------------|------------------------------|----------------------|
| | (m³/h) | (l/s) | | | | | | |
| 100KQL/W82-85-37/2 | 58 | 16.1 | 88 | 2960 | 66 | 37 | 4 | 361 |
| | 82 | 22.8 | 85 | | | | | |
| | 98.5 | 27.3 | 78 | | | | | |
| 100KQL/W90-101-45/2 | 63 | 17.5 | 105 | 2960 | 67 | 45 | 4 | 475 |
| | 90 | 25 | 101 | | | | | |
| | 108 | 30 | 94 | | | | | |
| 100KQL/W95-113-55/2 | 66 | 18.3 | 117 | 2960 | 68 | 55 | 4 | 618 |
| | 95 | 26.4 | 113 | | | | | |
| | 114 | 31.7 | 106 | | | | | |
| 100KQL/W100-125-75/2 | 70 | 19.4 | 129 | 2960 | 69 | 75 | 4 | 760 |
| | 100 | 27.8 | 125 | | | | | |
| | 120 | 33.3 | 118 | | | | | |
| 100KQL/W50-8-2.2/4 | 30 | 8.33 | 9.2 | 1480 | 77 | 2.2 | 3 | 120 |
| | 50 | 13.89 | 8 | | | | | |
| | 60 | 16.67 | 6.8 | | | | | |
| 100KQL/W45-10-2.2/4 | 26.8 | 7.44 | 10.7 | 1480 | 70 | 2.2 | 3 | 80 |
| | 44.6 | 12.4 | 9.9 | | | | | |
| | 53.5 | 14.9 | 9.4 | | | | | |
| 100KQL/W50-12.5-3/4 | 30 | 8.33 | 13.5 | 1480 | 71 | 3 | 3 | 93 |
| | 50 | 13.89 | 12.5 | | | | | |
| | 60 | 16.67 | 11.8 | | | | | |
| 100KQL/W47-17-4/4 | 28 | 7.78 | 18.6 | 1480 | 70 | 4 | 3 | 110 |
| | 46.7 | 12.97 | 17.4 | | | | | |
| | 56 | 15.56 | 16.6 | | | | | |
| 100KQL/W50-20-5.5/4 | 30 | 8.33 | 21.3 | 1480 | 71 | 5.5 | 3 | 139 |
| | 50 | 13.89 | 20 | | | | | |
| | 60 | 16.67 | 19 | | | | | |
| 100KQL/W47-28-7.5/4 | 28 | 7.78 | 29.6 | 1480 | 64 | 7.5 | 3 | 220 |
| | 46.7 | 12.97 | 27.9 | | | | | |
| | 56 | 15.56 | 26.1 | | | | | |
| 100KQL/W50-32-11/4 | 30 | 8.33 | 34 | 1480 | 65 | 11 | 3 | 236 |
| | 50 | 13.89 | 32 | | | | | |
| | 60 | 16.67 | 29 | | | | | |

尺寸图DIMENSION FIGURE

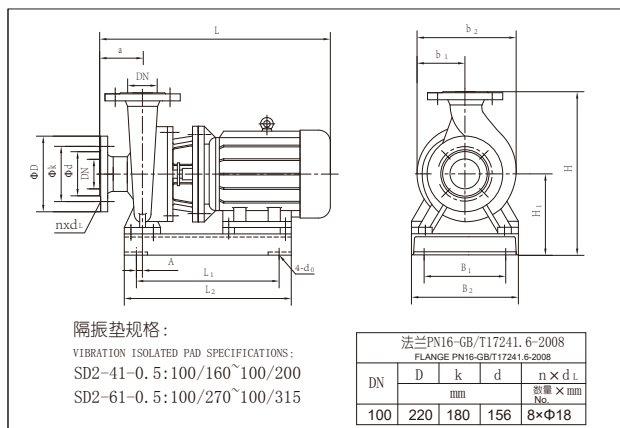

KQW尺寸表DIMENSION TABLE

| 型号 TYPE | 外形尺寸 Figure dimensions | | | | 安装尺寸 Installing dimensions | | | | | | | | DN |
|--------------------|---------------------------|-----|----------------|----------------|-------------------------------|-----|----------------|----------------|----------------|----------------|----------------|----|-----|
| | L | H | b ₂ | b ₁ | 4-φ ₀ | a | L ₁ | B ₁ | L ₂ | B ₂ | H ₁ | A | |
| 100KQW82-85-37/2 | 985 | 644 | 420 | 210 | 4-φ15 | 125 | 635 | 300 | 735 | 400 | 329 | 30 | 100 |
| 100KQW90-101-45/2 | 1020 | 634 | 470 | 235 | 4-φ20 | 125 | 665 | 310 | 765 | 440 | 319 | 30 | 100 |
| 100KQW95-113-55/2 | 1080 | 692 | 550 | 275 | 4-φ20 | 125 | 730 | 370 | 830 | 500 | 377 | 30 | 100 |
| 100KQW100-125-75/2 | 1150 | 696 | 580 | 290 | 4-φ20 | 125 | 800 | 430 | 900 | 560 | 381 | 30 | 100 |
| 100KQW50-8-2.2/4 | 615 | 516 | 292 | 140 | 4-φ15 | 100 | 315 | 180 | 430 | 280 | 251 | 10 | 100 |
| 100KQW45-10-2.2/4 | 640 | 595 | 355 | 167 | 4-φ15 | 125 | 315 | 280 | 430 | 360 | 305 | 10 | 100 |
| 100KQW50-12.5-3/4 | 640 | 595 | 355 | 167 | 4-φ15 | 125 | 315 | 280 | 430 | 360 | 305 | 10 | 100 |
| 100KQW47-17-4/4 | 675 | 595 | 355 | 167 | 4-φ15 | 125 | 315 | 280 | 440 | 360 | 305 | 10 | 100 |
| 100KQW50-20-5.5/4 | 705 | 595 | 355 | 167 | 4-φ15 | 125 | 355 | 280 | 470 | 360 | 305 | 20 | 100 |
| 100KQW47-28-7.5/4 | 765 | 649 | 397 | 189 | 4-φ15 | 125 | 400 | 315 | 535 | 400 | 334 | 20 | 100 |
| 100KQW50-32-11/4 | 855 | 649 | 397 | 189 | 4-φ15 | 125 | 450 | 315 | 600 | 400 | 334 | 30 | 100 |

性能曲线 CHARACTERISTIC CURVE

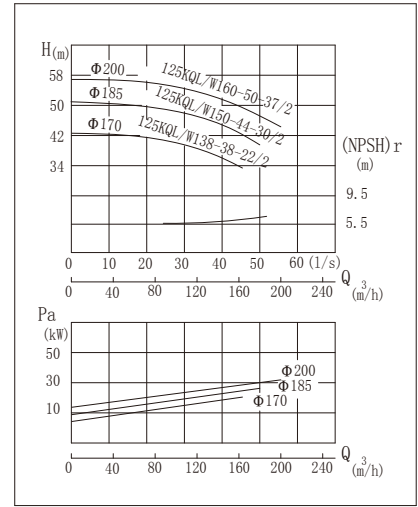
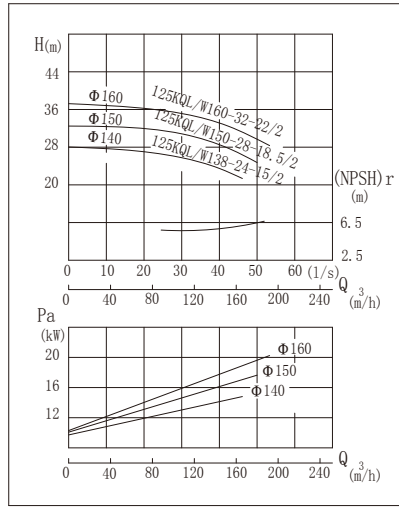
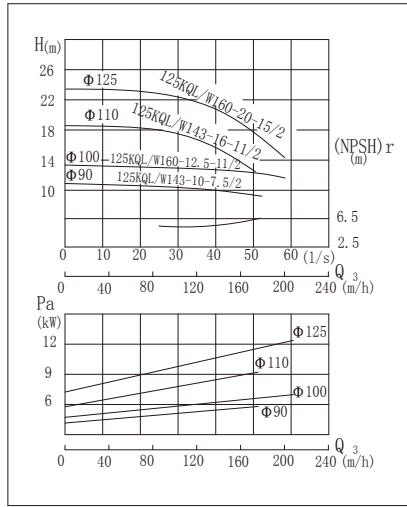

尺寸图 DIMENSION FIGURE

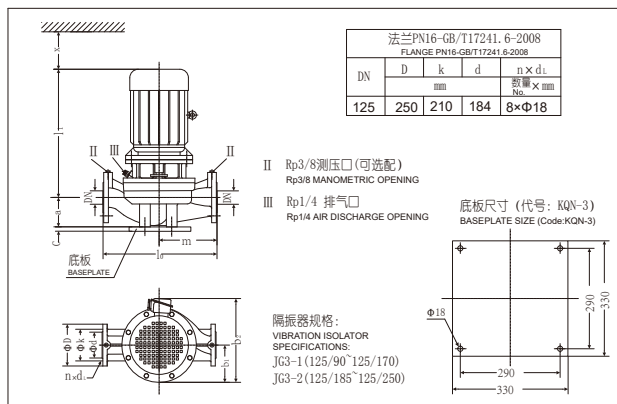

KQL尺寸表 DIMENSION TABLE

| 型号 TYPE | DN | l ₀ | m | a | c | l ₁ | b ₁ | b ₂ | x |
|---------------------|-----|----------------|-----|-----|----|----------------|----------------|----------------|-----|
| | | mm | | | | | | | |
| 125KQL143-10-7.5/2 | 125 | 645 | 320 | 220 | 30 | 585 | 150 | 360 | 130 |
| 125KQL160-12.5-11/2 | 125 | 645 | 320 | 220 | 30 | 710 | 175 | 430 | 130 |
| 125KQL143-16-11/2 | 125 | 645 | 320 | 220 | 30 | 710 | 225 | 485 | 130 |
| 125KQL160-20-15/2 | 125 | 645 | 320 | 220 | 30 | 715 | 225 | 485 | 130 |
| 125KQL138-24-15/2 | 125 | 645 | 320 | 220 | 30 | 715 | 225 | 485 | 130 |
| 125KQL150-28-18.5/2 | 125 | 645 | 320 | 220 | 30 | 747 | 225 | 485 | 130 |
| 125KQL160-32-22/2 | 125 | 645 | 320 | 220 | 30 | 789 | 250 | 530 | 130 |
| 125KQL138-38-22/2 | 125 | 700 | 350 | 210 | 30 | 792 | 250 | 530 | 140 |
| 125KQL150-44-30/2 | 125 | 700 | 350 | 210 | 30 | 860 | 270 | 575 | 140 |
| 125KQL160-50-37/2 | 125 | 700 | 350 | 210 | 30 | 860 | 270 | 575 | 140 |
| 125KQL138-60-37/2 | 125 | 700 | 350 | 210 | 30 | 860 | 270 | 575 | 140 |
| 125KQL150-70-45/2 | 125 | 700 | 350 | 210 | 30 | 895 | 295 | 625 | 140 |
| 125KQL160-80-55/2 | 125 | 700 | 350 | 210 | 30 | 955 | 315 | 680 | 140 |

性能曲线CHARACTERISTIC CURVE

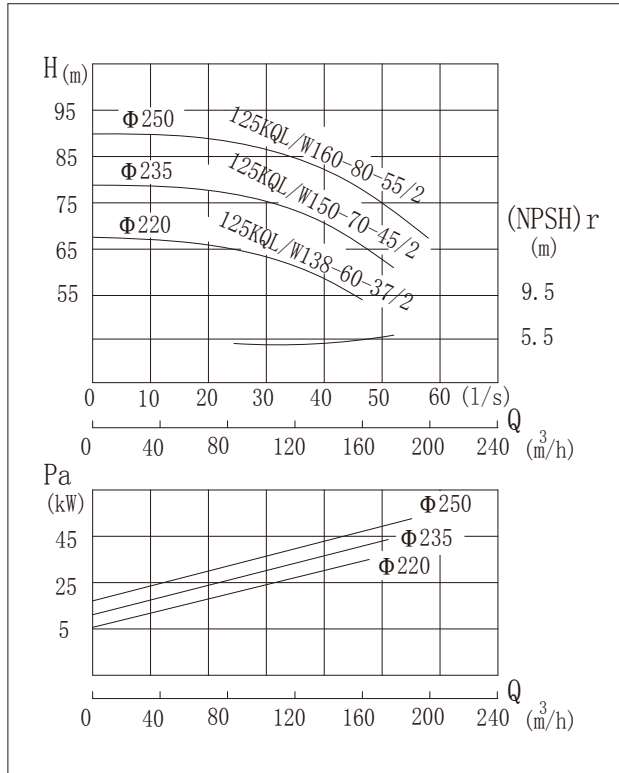

参数表PERFORMANCE DATA

| 型号 TYPE | 流量 Capacity | | 扬程 Head (m) | 转速 Speed (r/min) | 效率 Efficiency (%) | 电机 功率 Power (kW) | 必需汽蚀 余量 (NPSH)r (m) | 重量 Weight (kg) |
|-----------------------|----------------|-------|-------------------|------------------------|-------------------------|---------------------------|------------------------------|----------------------|
| | (m³/h) | (l/s) | | | | | | |
| 125KQL/W143-10-7.5/2 | 86 | 23.9 | 14 | 2960 | 74 | 7.5 | 5.5 | 170 |
| | 143 | 39.7 | 10 | | | | | |
| | 172 | 47.8 | 7 | | | | | |
| 125KQL/W160-12.5-11/2 | 96 | 26.7 | 18 | 2960 | 75 | 11 | 5.5 | 184 |
| | 160 | 44.4 | 12.5 | | | | | |
| | 192 | 53.3 | 8 | | | | | |
| 125KQL/W143-16-11/2 | 86 | 23.9 | 19.2 | 2960 | 79 | 11 | 5.5 | 185 |
| | 143 | 39.7 | 16 | | | | | |
| | 172 | 47.8 | 11.5 | | | | | |
| 125KQL/W160-20-15/2 | 96 | 26.7 | 25 | 2960 | 81 | 15 | 5.5 | 240 |
| | 160 | 44.4 | 20 | | | | | |
| | 192 | 53.3 | 17 | | | | | |
| 125KQL/W138-24-15/2 | 83 | 21.7 | 26 | 2960 | 80 | 15 | 5.5 | 241 |
| | 138 | 38.3 | 24 | | | | | |
| | 166 | 46.1 | 21 | | | | | |
| 125KQL/W150-28-18.5/2 | 90 | 25 | 31.5 | 2960 | 81 | 18.5 | 5.5 | 217 |
| | 150 | 41.7 | 28 | | | | | |
| | 180 | 50 | 24.5 | | | | | |
| 125KQL/W160-32-22/2 | 96 | 26.7 | 36 | 2960 | 82 | 22 | 5.5 | 258 |
| | 160 | 44.4 | 32 | | | | | |
| | 192 | 53.3 | 28 | | | | | |
| 125KQL/W138-38-22/2 | 83 | 21.7 | 41.3 | 2960 | 80 | 22 | 5.5 | 273 |
| | 138 | 38.3 | 37.5 | | | | | |
| | 166 | 46.1 | 34.5 | | | | | |
| 125KQL/W150-44-30/2 | 90 | 25 | 48.4 | 2960 | 81 | 30 | 5.5 | 366 |
| | 150 | 41.7 | 44 | | | | | |
| | 180 | 50 | 40.5 | | | | | |
| 125KQL/W160-50-37/2 | 96 | 26.7 | 55 | 2960 | 82 | 37 | 5.5 | 397 |
| | 160 | 44.4 | 50 | | | | | |
| | 192 | 53.3 | 46 | | | | | |
| 125KQL/W138-60-37/2 | 83 | 21.7 | 66 | 2960 | 78 | 37 | 5 | 504 |
| | 138 | 38.3 | 60 | | | | | |
| | 166 | 46.1 | 55 | | | | | |
| 125KQL/W150-70-45/2 | 90 | 25 | 76 | 2960 | 79 | 45 | 5 | 555 |
| | 150 | 41.7 | 70 | | | | | |
| | 180 | 50 | 64 | | | | | |
| 125KQL/W160-80-55/2 | 96 | 26.7 | 87 | 2960 | 80 | 55 | 5 | 636 |
| | 160 | 44.4 | 80 | | | | | |
| | 192 | 53.3 | 73 | | | | | |

尺寸图DIMENSION FIGURE

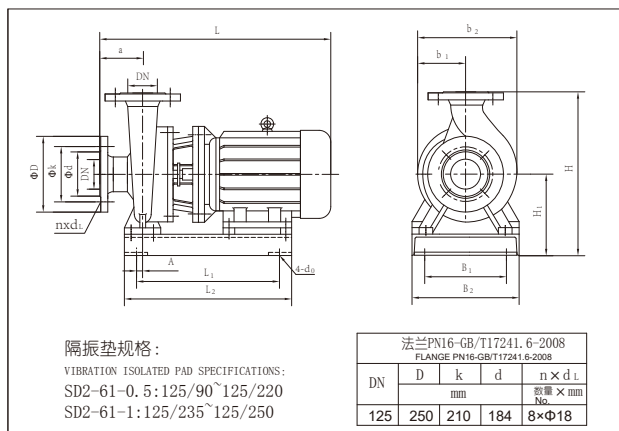

KQW尺寸表DIMENSION TABLE

| 型号 TYPE | 外形尺寸 Figure dimensions | | | | 安装尺寸 Installing dimensions | | | | | | | DN | |
|---------------------|---------------------------|-----|----------------|----------------|-------------------------------|-----|----------------|----------------|----------------|----------------|----------------|----|-----|
| | L | H | b ₂ | b ₁ | 4-φ ₀ | a | L ₁ | B ₁ | L ₂ | B ₂ | H ₁ | | A |
| 125KQW143-10-7.5/2 | 710 | 567 | 355 | 175 | 4-φ15 | 125 | 385 | 220 | 485 | 320 | 277 | 30 | 125 |
| 125KQW160-12.5-11/2 | 840 | 567 | 355 | 175 | 4-φ15 | 125 | 385 | 220 | 485 | 320 | 277 | 30 | 125 |
| 125KQW143-16-11/2 | 840 | 567 | 355 | 175 | 4-φ15 | 125 | 385 | 220 | 485 | 320 | 277 | 30 | 125 |
| 125KQW160-20-15/2 | 840 | 567 | 355 | 175 | 4-φ15 | 125 | 385 | 220 | 485 | 320 | 277 | 30 | 125 |
| 125KQW138-24-15/2 | 840 | 567 | 355 | 175 | 4-φ15 | 125 | 385 | 220 | 485 | 320 | 277 | 30 | 125 |
| 125KQW150-28-18.5/2 | 870 | 567 | 355 | 175 | 4-φ15 | 125 | 530 | 220 | 630 | 320 | 277 | 30 | 125 |
| 125KQW160-32-22/2 | 910 | 575 | 380 | 190 | 4-φ15 | 125 | 535 | 260 | 635 | 360 | 285 | 30 | 125 |
| 125KQW138-38-22/2 | 925 | 625 | 393 | 190 | 4-φ15 | 125 | 550 | 260 | 650 | 360 | 305 | 30 | 125 |
| 125KQW150-44-30/2 | 985 | 624 | 420 | 210 | 4-φ15 | 125 | 635 | 300 | 735 | 400 | 304 | 30 | 125 |
| 125KQW160-50-37/2 | 985 | 624 | 420 | 210 | 4-φ15 | 125 | 635 | 300 | 735 | 400 | 304 | 30 | 125 |
| 125KQW138-60-37/2 | 985 | 624 | 420 | 210 | 4-φ15 | 125 | 635 | 300 | 735 | 400 | 304 | 30 | 125 |
| 125KQW150-70-45/2 | 1020 | 639 | 470 | 235 | 4-φ20 | 125 | 665 | 310 | 765 | 440 | 319 | 30 | 125 |
| 125KQW160-80-55/2 | 1080 | 697 | 550 | 275 | 4-φ20 | 125 | 730 | 370 | 830 | 500 | 377 | 30 | 125 |

性能曲线CHARACTERISTIC CURVE

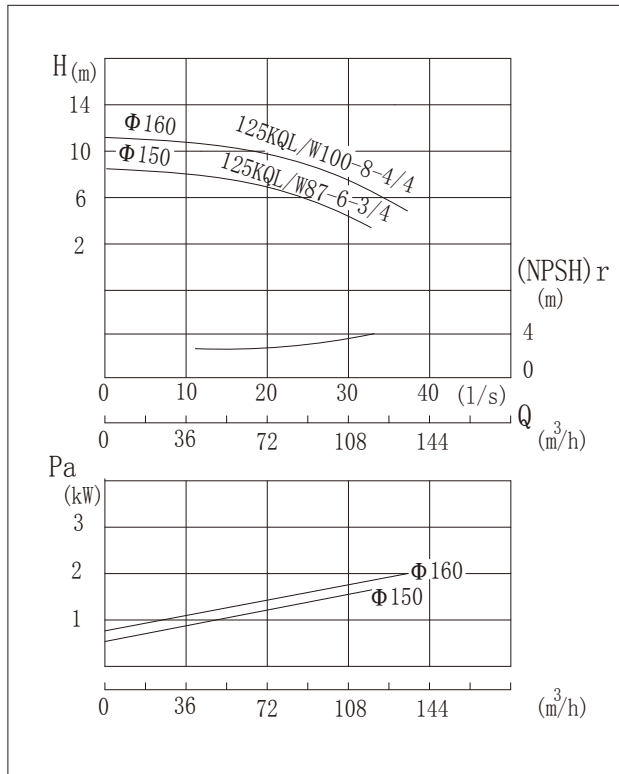

参数表PERFORMANCE DATA

| 型号 TYPE | 流量 Capacity | | 扬程 Head (m) | 转速 Speed (r/min) | 效率 Efficiency (%) | 电机 功率 Power (kW) | 必需汽蚀 余量 (NPSH) _r (m) | 重量 Weight (kg) |
|----------------------|--------------------|-------|-------------------|------------------------|-------------------------|---------------------------|--|----------------------|
| | ³ (m/h) | (l/s) | | | | | | |
| 125KQL/W134-88-55/2 | 80.5 | 22.4 | 96 | 2960 | 73 | 55 | 5 | 512 |
| | 134 | 37.2 | 88 | | | | | |
| | 161 | 44.7 | 81 | | | | | |
| 125KQL/W143-100-75/2 | 86 | 23.9 | 108 | 2960 | 74 | 75 | 5 | 766 |
| | 143 | 39.7 | 100 | | | | | |
| | 172 | 47.8 | 94 | | | | | |
| 125KQL/W150-110-75/2 | 90 | 25 | 115 | 2960 | 75 | 75 | 5 | 693 |
| | 150 | 41.7 | 110 | | | | | |
| | 180 | 50 | 102 | | | | | |
| 125KQL/W160-125-90/2 | 96 | 26.7 | 132 | 2960 | 76 | 90 | 5 | 808 |
| | 160 | 44.4 | 125 | | | | | |
| | 192 | 53.3 | 118 | | | | | |
| 125KQL/W100-5-2.2/4 | 60 | 16.67 | 6.5 | 1480 | 78 | 2.2 | 3 | 110 |
| | 100 | 27.8 | 5 | | | | | |
| | 120 | 33.33 | 4 | | | | | |
| 125KQL/W87-6-3/4 | 52 | 14.5 | 7.5 | 1480 | 79 | 3 | 3 | 113 |
| | 87 | 24.2 | 6.3 | | | | | |
| | 104 | 28.9 | 5.1 | | | | | |
| 125KQL/W100-8-4/4 | 60 | 16.67 | 9.4 | 1480 | 80 | 4 | 3 | 113 |
| | 100 | 27.8 | 8 | | | | | |
| | 120 | 33.33 | 6.7 | | | | | |

尺寸图DIMENSION FIGURE

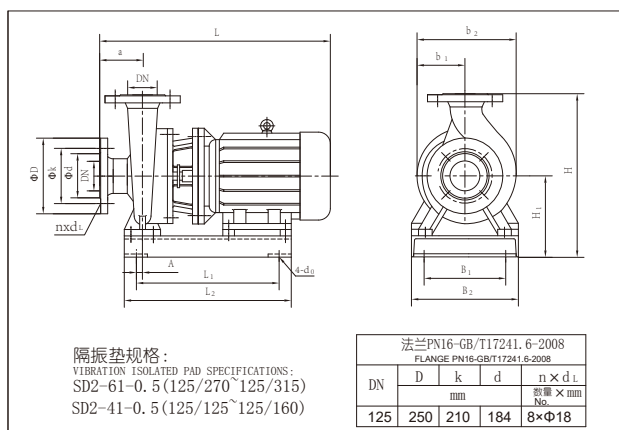

KQW尺寸表DIMENSION TABLE

| 型号 TYPE | 外形尺寸 Figure dimensions | | | | 安装尺寸 Installing dimensions | | | | | | | | DN |
|--------------------|---------------------------|-----|----------------|----------------|-------------------------------|-----|----------------|----------------|----------------|----------------|----------------|----|-----|
| | L | H | b ₂ | b ₁ | 4-φ ₀ | a | L ₁ | B ₁ | L ₂ | B ₂ | H ₁ | A | |
| 125KQW134-88-55/2 | 1095 | 667 | 550 | 275 | 4-φ20 | 125 | 730 | 370 | 830 | 500 | 347 | 30 | 125 |
| 125KQW143-100-75/2 | 1165 | 701 | 580 | 290 | 4-φ20 | 125 | 800 | 430 | 900 | 560 | 381 | 30 | 125 |
| 125KQW150-110-75/2 | 1165 | 701 | 580 | 290 | 4-φ20 | 125 | 800 | 430 | 900 | 560 | 381 | 30 | 125 |
| 125KQW160-125-90/2 | 1215 | 701 | 580 | 290 | 4-φ20 | 125 | 850 | 430 | 950 | 560 | 381 | 30 | 125 |
| 125KQW100-5-2.2/4 | 637 | 557 | 350 | 160 | 4-φ15 | 125 | 340 | 220 | 440 | 320 | 277 | 30 | 125 |
| 125KQW87-6-3/4 | 637 | 557 | 350 | 160 | 4-φ15 | 125 | 340 | 220 | 440 | 320 | 277 | 30 | 125 |
| 125KQW100-8-4/4 | 672 | 557 | 350 | 160 | 4-φ15 | 125 | 350 | 220 | 450 | 320 | 277 | 30 | 125 |

性能曲线 CHARACTERISTIC CURVE

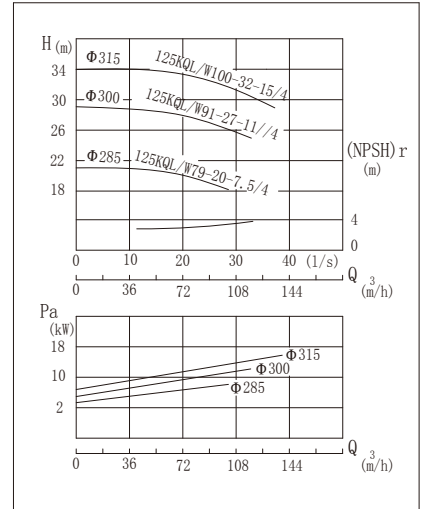
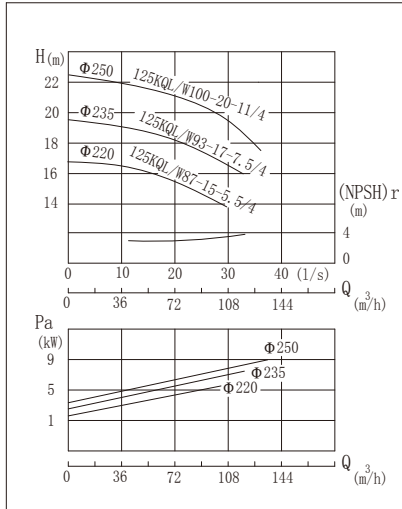
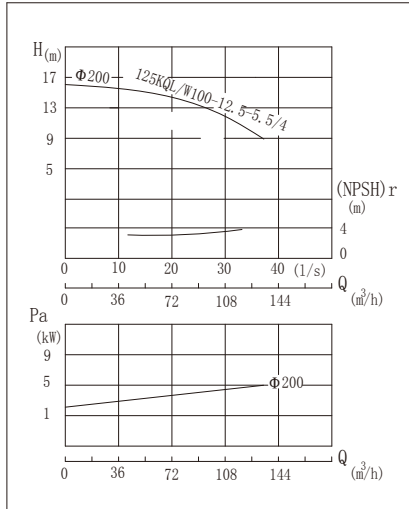

尺寸图 DIMENSION FIGURE

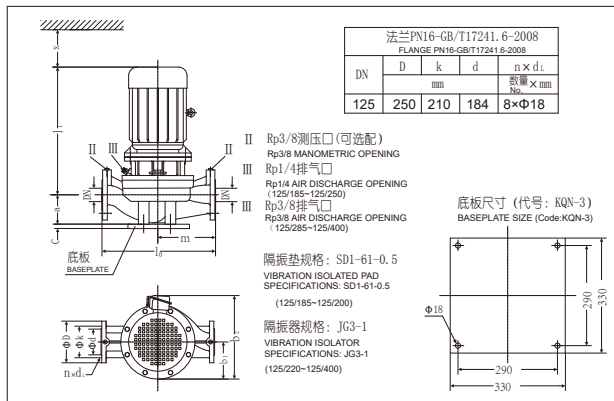

KQL尺寸表 DIMENSION TABLE

| 型号 TYPE | DN | l ₀ | m | a | c | l ₁ | b ₁ | b ₂ | x |
|----------------------|-----|----------------|-----|-----|----|----------------|----------------|----------------|-----|
| | | mm | | | | | | | |
| 125KQL100-12.5-5.5/4 | 125 | 700 | 335 | 200 | 30 | 588 | 185 | 395 | 130 |
| 125KQL87-15-5.5/4 | 125 | 700 | 335 | 200 | 30 | 588 | 185 | 395 | 130 |
| 125KQL93-17-7.5/4 | 125 | 700 | 335 | 200 | 30 | 638 | 185 | 395 | 130 |
| 125KQL120-16-7.5/4 | 125 | 700 | 335 | 200 | 30 | 638 | 185 | 395 | 130 |
| 125KQL100-20-11/4 | 125 | 700 | 335 | 200 | 30 | 718 | 225 | 485 | 130 |
| 125KQL79-20-7.5/4 | 125 | 785 | 385 | 210 | 30 | 638 | 240 | 515 | 130 |
| 125KQL91-27-11/4 | 125 | 785 | 385 | 210 | 30 | 732 | 240 | 515 | 130 |
| 125KQL100-32-15/4 | 125 | 785 | 385 | 210 | 30 | 762 | 240 | 515 | 130 |
| 125KQL87-38-18.5/4 | 125 | 785 | 385 | 210 | 30 | 802 | 250 | 530 | 130 |
| 125KQL94-44-22/4 | 125 | 785 | 385 | 210 | 30 | 852 | 250 | 530 | 130 |
| 125KQL100-50-30/4 | 125 | 785 | 385 | 210 | 30 | 862 | 270 | 575 | 130 |

性能曲线CHARACTERISTIC CURVE

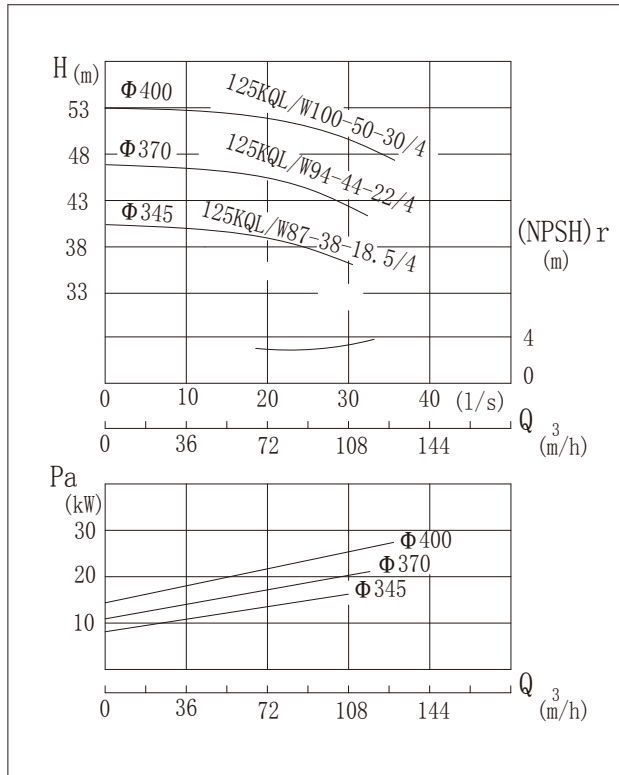

参数表PERFORMANCE DATA

| 型号 TYPE | 流量 Capacity | | 扬程 Head (m) | 转速 Speed (r/min) | 效率 Efficiency (%) | 电机 功率 Power (kW) | 必需汽蚀 余量 (NPSH) _r (m) | 重量 Weight (kg) |
|------------------------|---------------------|-------|-------------------|------------------------|-------------------------|---------------------------|--|----------------------|
| | (m ³ /h) | (l/s) | | | | | | |
| 125KQL/W100-12.5-5.5/4 | 60 | 16.67 | 14 | 1480 | 78 | 5.5 | 3 | 185 |
| | 100 | 27.8 | 12.5 | | | | | |
| | 120 | 33.33 | 11 | | | | | |
| 125KQL/W87-15-5.5/4 | 52 | 14.5 | 16.4 | 1480 | 76 | 5.5 | 3 | 208 |
| | 87 | 24.2 | 15 | | | | | |
| | 104 | 28.9 | 14 | | | | | |
| 125KQL/W93-17-7.5/4 | 56 | 15.6 | 19 | 1480 | 77 | 7.5 | 3 | 220 |
| | 93 | 25.8 | 17.4 | | | | | |
| | 112 | 31.1 | 15.5 | | | | | |
| 125KQL/W120-16-7.5/4 | 84 | 23.3 | 18.5 | 1480 | 78 | 7.5 | 3 | 220 |
| | 120 | 33.3 | 16 | | | | | |
| | 132 | 36.7 | 14.4 | | | | | |
| 125KQL/W100-20-11/4 | 60 | 16.7 | 21.5 | 1480 | 78 | 11 | 3 | 280 |
| | 100 | 27.8 | 20 | | | | | |
| | 120 | 33.3 | 18 | | | | | |
| 125KQL/W79-20-7.5/4 | 47 | 13.1 | 21 | 1480 | 72 | 7.5 | 3 | 230 |
| | 79 | 21.9 | 20 | | | | | |
| | 95 | 26.4 | 18 | | | | | |
| 125KQL/W91-27-11/4 | 55 | 15.3 | 29 | 1480 | 73 | 11 | 3 | 276 |
| | 91 | 25.3 | 27 | | | | | |
| | 110 | 30.6 | 22 | | | | | |
| 125KQL/W100-32-15/4 | 60 | 16.7 | 35 | 1480 | 74 | 15 | 3 | 305 |
| | 100 | 27.8 | 32 | | | | | |
| | 120 | 33.3 | 27 | | | | | |
| 125KQL/W87-38-18.5/4 | 52.3 | 14.5 | 39 | 1480 | 67 | 18.5 | 3 | 311 |
| | 87 | 24.2 | 38 | | | | | |
| | 105 | 29.2 | 37 | | | | | |
| 125KQL/W94-44-22/4 | 56.4 | 15.7 | 46 | 1480 | 68 | 22 | 3 | 368 |
| | 94 | 26.1 | 44 | | | | | |
| | 113 | 31.4 | 41 | | | | | |
| 125KQL/W100-50-30/4 | 60 | 16.7 | 52 | 1480 | 69 | 30 | 3 | 450 |
| | 100 | 27.8 | 50 | | | | | |
| | 120 | 33.3 | 47 | | | | | |

尺寸图DIMENSION FIGURE

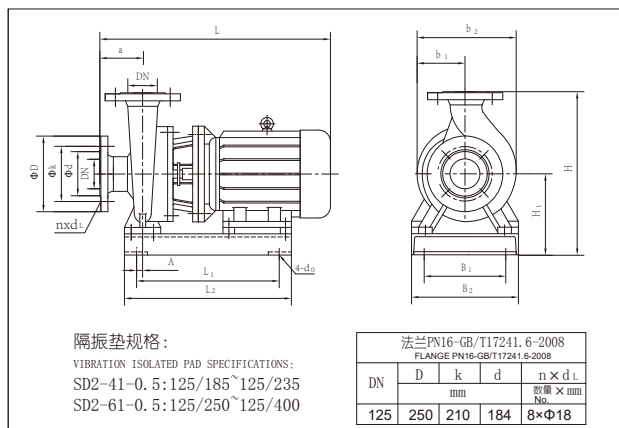

KQW尺寸表DIMENSION TABLE

| 型号 TYPE | 外形尺寸 Figure dimensions | | | | 安装尺寸 Installing dimensions | | | | | | | | DN |
|----------------------|---------------------------|-----|----------------|----------------|-------------------------------|-----|----------------|----------------|----------------|----------------|----------------|----|-----|
| | L | H | b ₂ | b ₁ | 4-φ ₀ | a | L ₁ | B ₁ | L ₂ | B ₂ | H ₁ | A | |
| 125KQW100-12.5-5.5/4 | 702 | 669 | 412 | 200 | 4-φ15 | 125 | 390 | 300 | 490 | 400 | 334 | 30 | 125 |
| 125KQW87-15-5.5/4 | 702 | 669 | 412 | 200 | 4-φ15 | 125 | 390 | 300 | 490 | 400 | 334 | 30 | 125 |
| 125KQW93-17-7.5/4 | 752 | 669 | 412 | 200 | 4-φ15 | 125 | 425 | 300 | 525 | 400 | 334 | 30 | 125 |
| 125KQW120-16-7.5/4 | 752 | 669 | 412 | 200 | 4-φ15 | 125 | 425 | 300 | 525 | 400 | 334 | 30 | 125 |
| 125KQW100-20-11/4 | 842 | 669 | 412 | 200 | 4-φ15 | 125 | 485 | 300 | 585 | 400 | 334 | 30 | 125 |
| 125KQW79-20-7.5/4 | 767 | 767 | 518 | 250 | 4-φ20 | 125 | 460 | 370 | 560 | 500 | 382 | 50 | 125 |
| 125KQW91-27-11/4 | 857 | 767 | 518 | 250 | 4-φ20 | 125 | 520 | 370 | 620 | 500 | 382 | 50 | 125 |
| 125KQW100-32-15/4 | 887 | 767 | 518 | 250 | 4-φ20 | 125 | 565 | 370 | 665 | 500 | 382 | 50 | 125 |
| 125KQW87-38-18.5/4 | 927 | 767 | 518 | 250 | 4-φ20 | 125 | 570 | 370 | 670 | 500 | 382 | 50 | 125 |
| 125KQW94-44-22/4 | 977 | 767 | 518 | 250 | 4-φ20 | 125 | 610 | 370 | 710 | 500 | 382 | 50 | 125 |
| 125KQW100-50-30/4 | 987 | 762 | 518 | 250 | 4-φ20 | 125 | 660 | 370 | 760 | 500 | 377 | 50 | 125 |

性能曲线 CHARACTERISTIC CURVE

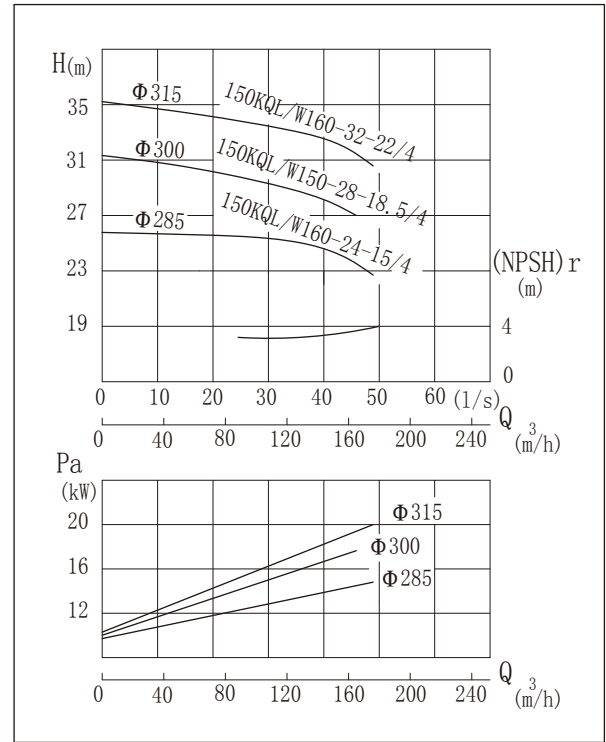
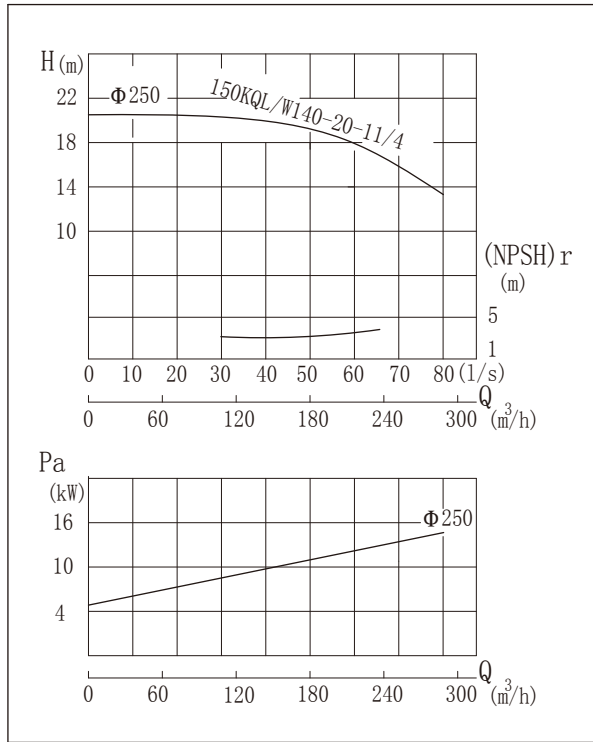

尺寸图 DIMENSION FIGURE

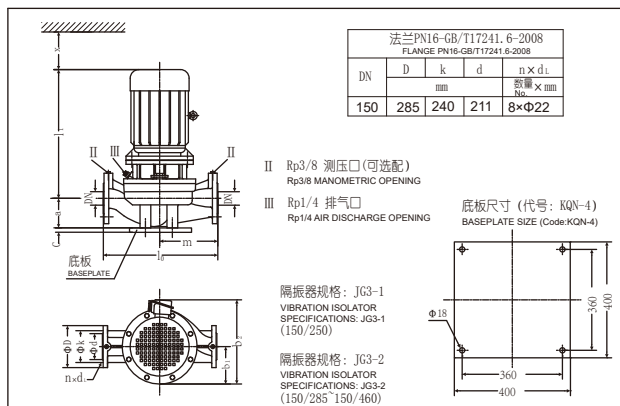

KQL尺寸表 DIMENSION TABLE

| 型号 | DN | l_0 | m | a | c | l_1 | b_1 | b_2 | x |
|---------------------|-----|-------|-----|-----|----|-------|-------|-------|-----|
| | mm | | | | | | | | |
| 150KQL140-20-11/4 | 150 | 880 | 430 | 265 | 37 | 725 | 225 | 485 | 150 |
| 150KQL160-24-15/4 | 150 | 880 | 430 | 274 | 37 | 758 | 250 | 530 | 155 |
| 150KQL150-28-18.5/4 | 150 | 880 | 430 | 274 | 37 | 795 | 250 | 530 | 155 |
| 150KQL160-32-22/4 | 150 | 880 | 430 | 274 | 37 | 845 | 250 | 530 | 155 |
| 150KQL138-38-22/4 | 150 | 880 | 430 | 274 | 37 | 845 | 250 | 530 | 155 |
| 150KQL150-44-30/4 | 150 | 970 | 480 | 280 | 37 | 845 | 270 | 575 | 155 |
| 150KQL160-50-37/4 | 150 | 970 | 480 | 280 | 37 | 859 | 295 | 625 | 155 |

性能曲线CHARACTERISTIC CURVE

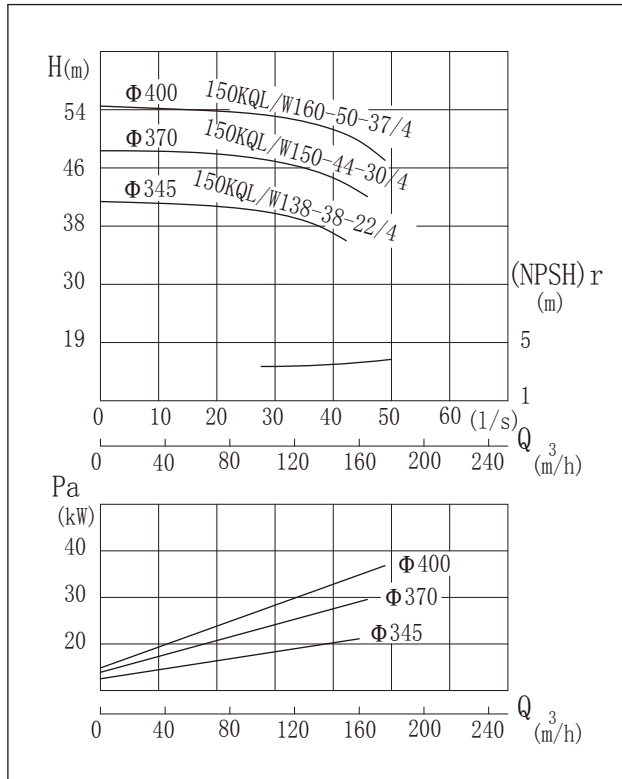

参数表PERFORMANCE DATA

| 型号 TYPE | 流量 Capacity | | 扬程 Head (m) | 转速 Speed (r/min) | 效率 Efficiency (%) | 电机 功率 Power (kW) | 必需汽蚀 余量 (NPSH)r (m) | 重量 Weight (kg) |
|-----------------------|----------------|-------|-------------------|------------------------|-------------------------|---------------------------|------------------------------|----------------------|
| | (m³/h) | (l/s) | | | | | | |
| 150KQL/W140-20-11/4 | 98 | 27.2 | 21 | 1480 | 79 | 11 | 3 | 260 |
| | 140 | 38.9 | 20 | | | | | |
| | 154 | 42.8 | 18.4 | | | | | |
| 150KQL/W160-24-15/4 | 112 | 31.1 | 25.2 | 1480 | 76 | 15 | 3 | 300 |
| | 160 | 44.4 | 24 | | | | | |
| | 176 | 48.9 | 22.5 | | | | | |
| 150KQL/W150-28-18.5/4 | 105 | 29.2 | 29.4 | 1480 | 78 | 18.5 | 3 | 330 |
| | 150 | 41.7 | 28 | | | | | |
| | 165 | 45.8 | 26.5 | | | | | |
| 150KQL/W160-32-22/4 | 112 | 31.1 | 33.6 | 1480 | 79 | 22 | 3 | 350 |
| | 160 | 44.4 | 32 | | | | | |
| | 176 | 48.9 | 30 | | | | | |
| 150KQL/W138-38-22/4 | 96.6 | 26.8 | 39.9 | 1480 | 72 | 22 | 3.5 | 352 |
| | 138 | 38.3 | 38 | | | | | |
| | 151.8 | 42.2 | 36.2 | | | | | |
| 150KQL/W150-44-30/4 | 105 | 29.2 | 46.2 | 1480 | 73 | 30 | 3.5 | 423 |
| | 150 | 41.7 | 44 | | | | | |
| | 165 | 45.8 | 41.5 | | | | | |
| 150KQL/W160-50-37/4 | 112 | 31.1 | 52.5 | 1480 | 74.7 | 37 | 3.5 | 440 |
| | 160 | 44.4 | 50 | | | | | |
| | 176 | 48.9 | 47 | | | | | |

尺寸图DIMENSION FIGURE

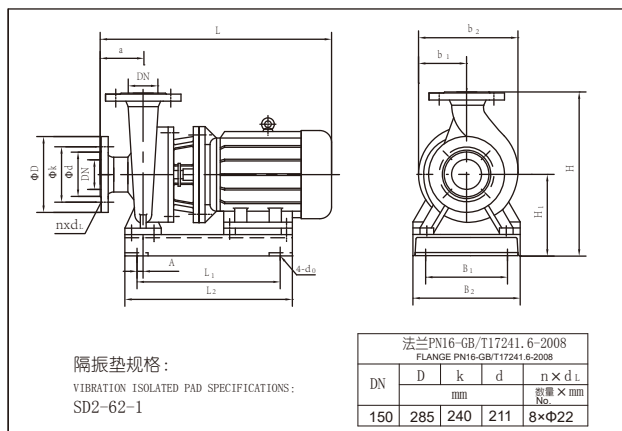

KQW尺寸表DIMENSION TABLE

| 型号 TYPE | 外形尺寸 | | 安装尺寸 | | | | | | | | | | DN |
|---------------------|-------------------|-----|-----------------------|----------------|-------------------|-----|----------------|----------------|----------------|----------------|----------------|----|-----|
| | Figure dimensions | | Installing dimensions | | | | | | | | | | |
| | L | H | b ₂ | b ₁ | 4-φd ₀ | a | L ₁ | B ₁ | L ₂ | B ₂ | H ₁ | A | |
| 150KQW140-20-11/4 | 872 | 759 | 433 | 200 | 4-φ15 | 140 | 500 | 300 | 600 | 400 | 359 | 30 | 150 |
| 150KQW160-24-15/4 | 902 | 759 | 433 | 250 | 4-φ20 | 140 | 545 | 300 | 645 | 400 | 359 | 30 | 150 |
| 150KQW150-28-18.5/4 | 945 | 812 | 530 | 250 | 4-φ20 | 140 | 565 | 370 | 665 | 500 | 382 | 50 | 150 |
| 150KQW160-32-22/4 | 995 | 812 | 530 | 250 | 4-φ20 | 140 | 600 | 370 | 700 | 500 | 382 | 50 | 150 |
| 150KQW138-38-22/4 | 995 | 812 | 530 | 250 | 4-φ20 | 140 | 600 | 370 | 700 | 500 | 382 | 50 | 150 |
| 150KQW150-44-30/4 | 996 | 867 | 530 | 250 | 4-φ20 | 140 | 650 | 370 | 750 | 500 | 417 | 50 | 150 |
| 150KQW160-50-37/4 | 1006 | 862 | 530 | 250 | 4-φ20 | 140 | 655 | 370 | 762 | 500 | 412 | 50 | 150 |

性能曲线CHARACTERISTIC CURVE

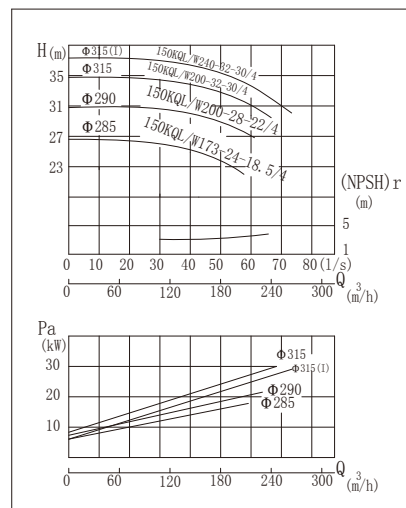
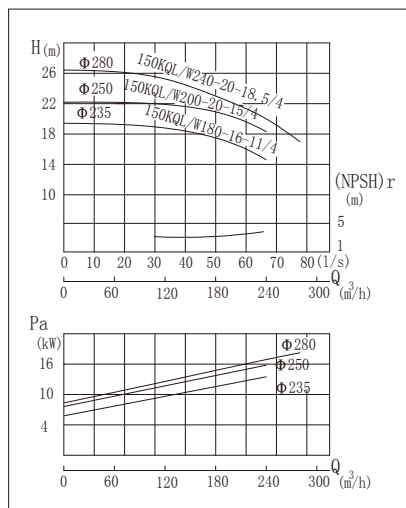
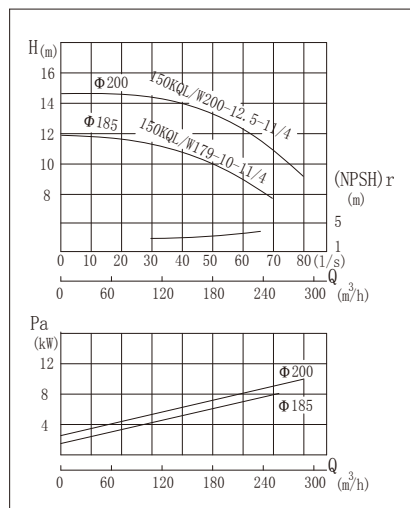

尺寸图DIMENSION FIGURE

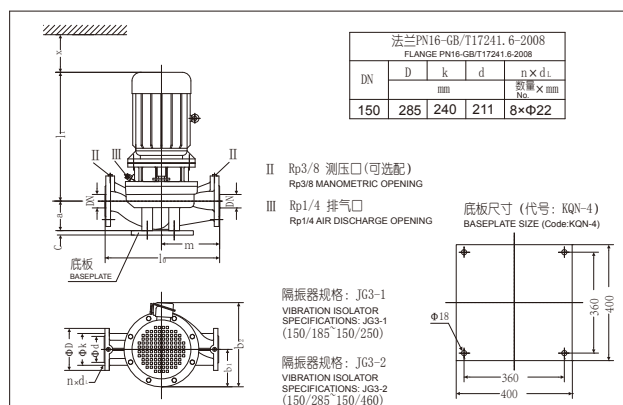

KQL尺寸表DIMENSION TABLE

| 型号 | DN | l ₀ | m | a | c | l ₁ | b ₁ | b ₂ | x |
|---------------------|-----|----------------|-----|-----|----|----------------|----------------|----------------|-----|
| | mm | | | | | | | | |
| 150KQL179-10-11/4 | 150 | 880 | 430 | 265 | 37 | 725 | 225 | 485 | 150 |
| 150KQL200-12.5-11/4 | 150 | 880 | 430 | 265 | 37 | 725 | 225 | 485 | 150 |
| 150KQL180-16-11/4 | 150 | 880 | 430 | 265 | 37 | 725 | 225 | 485 | 150 |
| 150KQL200-20-15/4 | 150 | 880 | 430 | 265 | 37 | 757 | 225 | 485 | 150 |
| 150KQL240-20-18.5/4 | 150 | 880 | 430 | 265 | 37 | 797 | 225 | 485 | 150 |
| 150KQL173-24-18.5/4 | 150 | 880 | 430 | 274 | 37 | 795 | 250 | 530 | 155 |
| 150KQL200-28-22/4 | 150 | 880 | 430 | 274 | 37 | 845 | 250 | 530 | 155 |
| 150KQL200-32-30/4 | 150 | 880 | 430 | 274 | 37 | 845 | 270 | 575 | 155 |
| 150KQL240-32-30/4 | 150 | 880 | 430 | 274 | 37 | 845 | 270 | 575 | 155 |
| 150KQL200-38-30/4 | 150 | 880 | 430 | 274 | 37 | 845 | 270 | 575 | 155 |
| 150KQL187-44-37/4 | 150 | 970 | 480 | 280 | 37 | 859 | 295 | 625 | 155 |
| 150KQL200-50-45/4 | 150 | 970 | 480 | 280 | 37 | 887 | 295 | 625 | 155 |

性能曲线CHARACTERISTIC CURVE

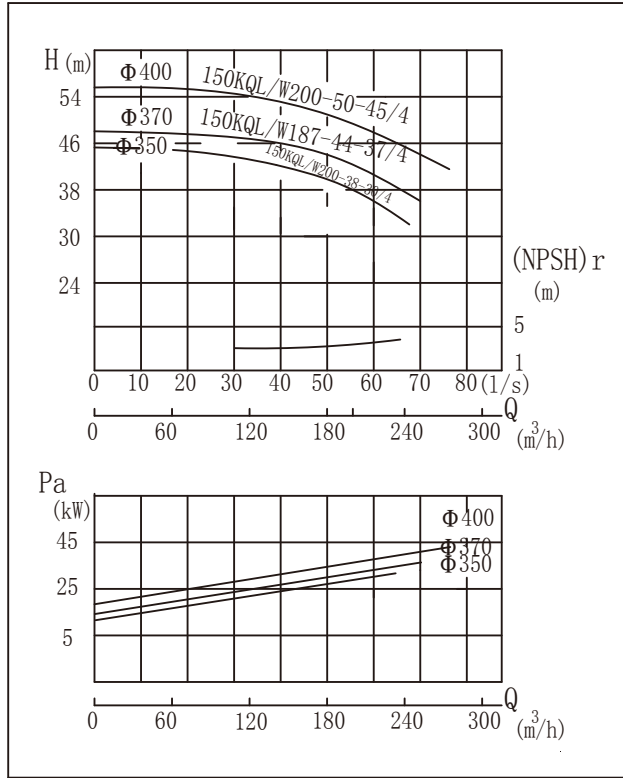

参数表PERFORMANCE DATA

| 型号 TYPE | 流量 Capacity | | 扬程 Head (m) | 转速 Speed (r/min) | 效率 Efficiency (%) | 电机 功率 Power (kW) | 必需汽蚀余量 (NPSH) _r (m) | 重量 Weight (kg) |
|-----------------------|----------------|-------|-------------------|------------------------|-------------------------|---------------------------|--------------------------------------|----------------------|
| | (m³/h) | (l/s) | | | | | | |
| 150KQL/W179-10-11/4 | 125 | 34.7 | 11.6 | 1480 | 80 | 11 | 3 | 260 |
| | 179 | 49.7 | 10 | | | | | |
| | 215 | 59.7 | 8 | | | | | |
| 150KQL/W200-12.5-11/4 | 140 | 38.9 | 14.1 | 1480 | 82 | 11 | 3 | 265 |
| | 200 | 55.6 | 12.5 | | | | | |
| | 240 | 66.7 | 10.6 | | | | | |
| 150KQL/W180-16-11/4 | 126 | 35.0 | 16.8 | 1480 | 81.8 | 11 | 3 | 270 |
| | 180 | 50.0 | 16 | | | | | |
| | 198 | 55.0 | 14.4 | | | | | |
| 150KQL/W200-20-15/4 | 140 | 38.9 | 21.8 | 1480 | 82.8 | 15 | 3 | 278 |
| | 200 | 55.6 | 20 | | | | | |
| | 220 | 61.1 | 18.5 | | | | | |
| 150KQL/W240-20-18.5/4 | 180 | 50.0 | 23 | 1480 | 82 | 18.5 | 3 | 315 |
| | 240 | 66.7 | 20 | | | | | |
| | 280 | 77.8 | 17 | | | | | |
| 150KQL/W173-24-18.5/4 | 121 | 33.6 | 25.8 | 1480 | 79 | 18.5 | 3.5 | 324 |
| | 173 | 48.1 | 24 | | | | | |
| | 208 | 57.8 | 20.7 | | | | | |
| 150KQL/W200-28-22/4 | 140 | 38.9 | 31 | 1480 | 81.7 | 22 | 3.5 | 345 |
| | 200 | 55.6 | 28 | | | | | |
| | 220 | 61.1 | 25.2 | | | | | |
| 150KQL/W200-32-30/4 | 140 | 38.9 | 35 | 1480 | 81.7 | 30 | 3.5 | 402 |
| | 200 | 55.6 | 32 | | | | | |
| | 240 | 66.7 | 28 | | | | | |
| 150KQL/W240-32-30/4 | 171 | 47.5 | 35.2 | 1480 | 80 | 30 | 4 | 430 |
| | 240 | 66.7 | 32 | | | | | |
| | 264 | 73.3 | 28.8 | | | | | |
| 150KQL/W200-38-30/4 | 140 | 38.9 | 39.9 | 1480 | 77 | 30 | 3.5 | 430 |
| | 200 | 55.6 | 38 | | | | | |
| | 220 | 58.3 | 36 | | | | | |
| 150KQL/W187-44-37/4 | 131 | 36.4 | 46.6 | 1480 | 76 | 37 | 3.5 | 510 |
| | 187 | 51.9 | 44 | | | | | |
| | 225 | 62.5 | 39 | | | | | |
| 150KQL/W200-50-45/4 | 140 | 38.9 | 53 | 1480 | 77 | 45 | 3.5 | 531 |
| | 200 | 55.6 | 50 | | | | | |
| | 240 | 66.7 | 44 | | | | | |

尺寸图DIMENSION FIGURE

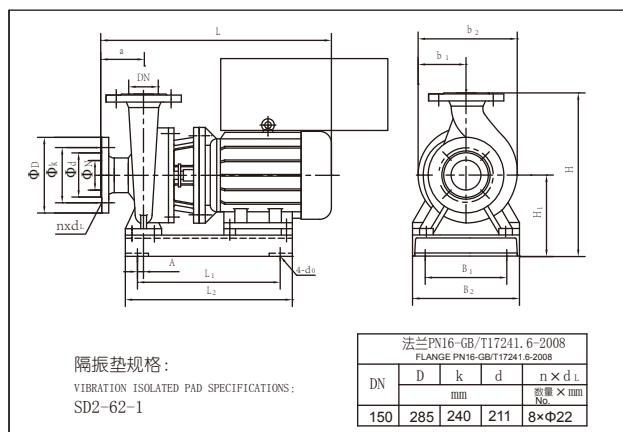

KQW尺寸表DIMENSION TABLE

| 型号 TYPE | 外形尺寸 Figure dimensions | | | | 安装尺寸 Installing dimensions | | | | | | | DN1 | |
|---------------------|---------------------------|-----|----------------|----------------|-------------------------------|-----|----------------|----------------|----------------|----------------|----------------|-----|-----|
| | L | H | b ₂ | b ₁ | 4-φ _a | a | L ₁ | B ₁ | L ₂ | B ₂ | H ₁ | | A |
| 150KQW179-10-11/4 | 872 | 759 | 433 | 200 | 4-φ15 | 140 | 500 | 300 | 600 | 400 | 359 | 30 | 150 |
| 150KQW200-12.5-11/4 | 872 | 759 | 433 | 200 | 4-φ15 | 140 | 500 | 300 | 600 | 400 | 359 | 30 | 150 |
| 150KQW180-16-11/4 | 872 | 759 | 433 | 200 | 4-φ15 | 140 | 500 | 300 | 600 | 400 | 359 | 30 | 150 |
| 150KQW200-20-15/4 | 905 | 759 | 433 | 200 | 4-φ15 | 140 | 545 | 300 | 645 | 400 | 359 | 30 | 150 |
| 150KQW240-20-18.5/4 | 945 | 759 | 433 | 200 | 4-φ15 | 140 | 550 | 300 | 655 | 410 | 359 | 30 | 150 |
| 150KQW173-24-18.5/4 | 945 | 812 | 530 | 250 | 4-φ20 | 140 | 565 | 370 | 665 | 500 | 382 | 50 | 150 |
| 150KQW200-28-22/4 | 995 | 812 | 530 | 250 | 4-φ20 | 140 | 600 | 370 | 700 | 500 | 382 | 50 | 150 |
| 150KQW200-32-30/4 | 995 | 809 | 530 | 250 | 4-φ20 | 140 | 650 | 370 | 750 | 500 | 379 | 50 | 150 |
| 150KQW240-32-30/4 | 995 | 809 | 530 | 250 | 4-φ20 | 140 | 650 | 370 | 750 | 500 | 379 | 50 | 150 |
| 150KQW200-38-30/4 | 995 | 809 | 530 | 250 | 4-φ20 | 140 | 650 | 370 | 750 | 500 | 379 | 50 | 150 |
| 150KQW187-44-37/4 | 1005 | 864 | 530 | 250 | 4-φ20 | 140 | 655 | 370 | 762 | 500 | 414 | 50 | 150 |
| 150KQW200-50-45/4 | 1030 | 864 | 530 | 250 | 4-φ20 | 140 | 680 | 370 | 780 | 500 | 414 | 50 | 150 |

性能曲线 CHARACTERISTIC CURVE

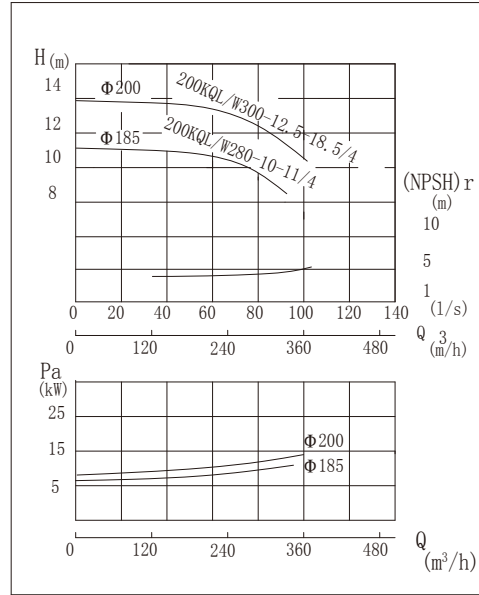
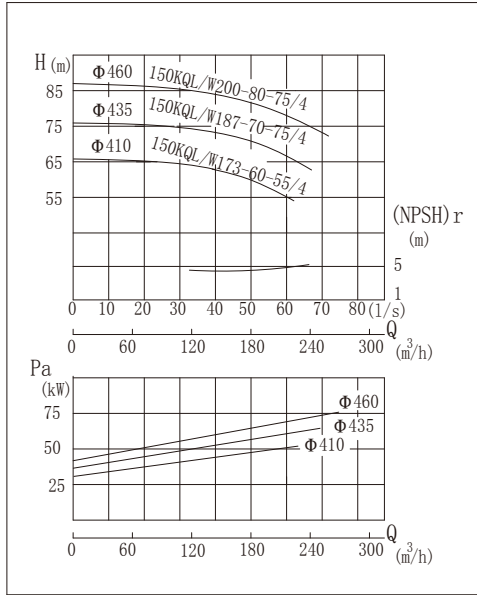

尺寸图 DIMENSION FIGURE

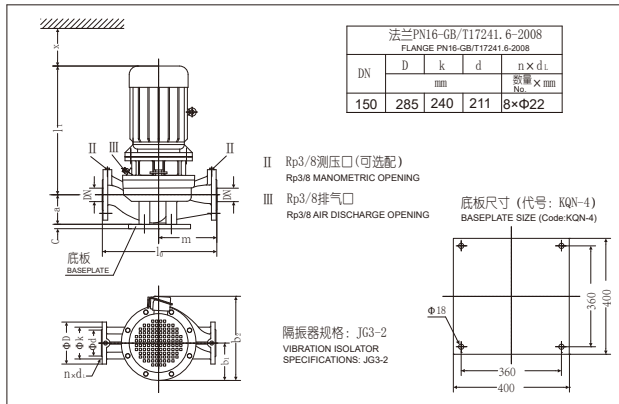

KQL尺寸表 DIMENSION TABLE

| 型号 TYPE | DN | l_0 | m | a | c | l_1 | b_1 | b_2 | x |
|-------------------|-----|-------|-----|-----|-----|-------|-------|-------|-----|
| | | mm | | | | | | | |
| 150KQL173-60-55/4 | 150 | 1050 | 500 | 280 | 37 | 965 | 315 | 680 | 165 |
| 150KQL187-70-75/4 | 150 | 1050 | 500 | 280 | 37 | 1030 | 360 | 760 | 165 |
| 150KQL200-80-75/4 | 150 | 1050 | 500 | 280 | 37 | 1030 | 360 | 760 | 165 |

尺寸图 DIMENSION FIGURE

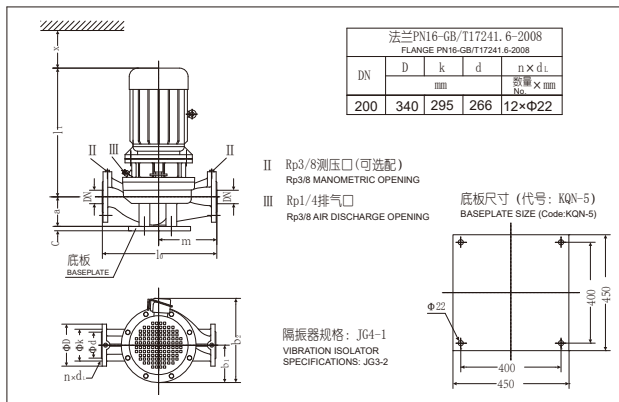

KQL尺寸表 DIMENSION TABLE

| 型号 TYPE | DN | l_0 | m | a | c | l_1 | b_1 | b_2 | x |
|---------------------|-----|-------|-----|-----|-----|-------|-------|-------|-----|
| | | mm | | | | | | | |
| 200KQL280-10-11/4 | 200 | 990 | 480 | 275 | 37 | 751 | 250 | 495 | 150 |
| 200KQL300-12.5-15/4 | 200 | 990 | 480 | 275 | 37 | 781 | 250 | 495 | 150 |
| 200KQL280-16-18.5/4 | 200 | 990 | 480 | 275 | 37 | 823 | 250 | 530 | 150 |
| 200KQL300-20-22/4 | 200 | 990 | 480 | 275 | 37 | 873 | 250 | 530 | 150 |

性能曲线CHARACTERISTIC CURVE

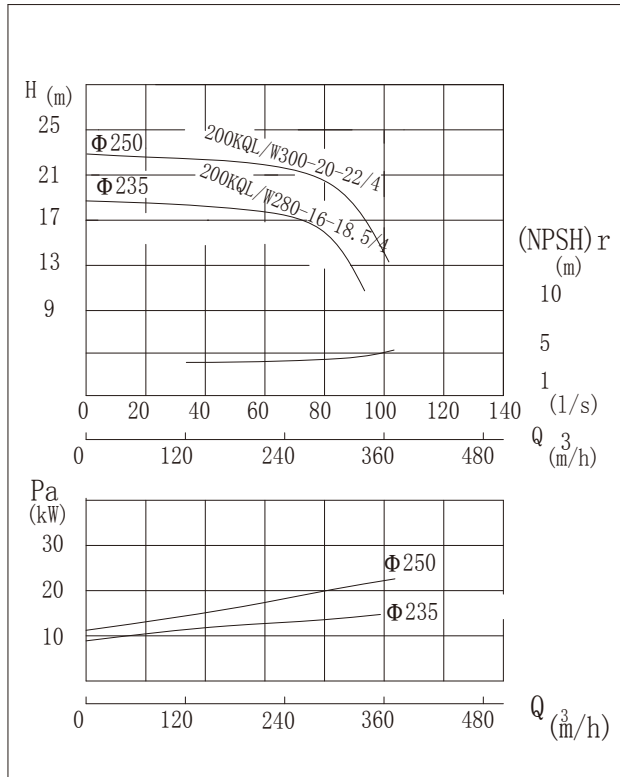

参数表PERFORMANCE DATA

| 型号 TYPE | 流量 Capacity | | 扬程 Head (m) | 转速 Speed (r/min) | 效率 Efficiency (%) | 电机 功率 Power (kW) | 必需汽蚀 余量 (NPSH) _r (m) | 重量 Weight (kg) |
|-----------------------|----------------|-------|-------------------|------------------------|-------------------------|---------------------------|--|----------------------|
| | (m³/h) | (l/s) | | | | | | |
| 150KQL/W173-60-55/4 | 121 | 33.6 | 64 | 1480 | 69 | 55 | 4 | 703 |
| | 173 | 48.1 | 60 | | | | | |
| | 208 | 57.7 | 55.5 | | | | | |
| 150KQL/W180-70-55/2 | 126 | 35.0 | 75 | 2960 | 74 | 55 | 6 | 590 |
| | 180 | 50.0 | 70 | | | | | |
| | 216 | 60.0 | 64 | | | | | |
| 150KQL/W187-70-75/4 | 131 | 36.4 | 74 | 1480 | 70 | 75 | 4 | 848 |
| | 187 | 51.9 | 70 | | | | | |
| | 224 | 62.3 | 64 | | | | | |
| 150KQL/W200-80-75/2 | 140 | 38.9 | 86 | 2960 | 75 | 75 | 6 | 630 |
| | 200 | 55.6 | 80 | | | | | |
| | 240 | 66.7 | 72 | | | | | |
| 150KQL/W200-80-75/4 | 140 | 38.9 | 85 | 1480 | 71.3 | 75 | 4 | 856 |
| | 200 | 55.6 | 80 | | | | | |
| | 240 | 66.7 | 75 | | | | | |
| 200KQL/W280-10-11/4 | 196 | 54.4 | 11.5 | 1480 | 82 | 11 | 4 | 326 |
| | 280 | 77.8 | 10 | | | | | |
| | 308 | 85.6 | 8.6 | | | | | |
| 200KQL/W300-12.5-15/4 | 210 | 58.3 | 15 | 1480 | 83 | 15 | 4 | 345 |
| | 300 | 83.3 | 12.5 | | | | | |
| | 330 | 91.7 | 11 | | | | | |
| 200KQL/W280-16-18.5/4 | 196 | 54.4 | 18 | 1480 | 82 | 18.5 | 4 | 339 |
| | 280 | 77.8 | 16 | | | | | |
| | 336 | 93.3 | 13 | | | | | |
| 200KQL/W300-20-22/4 | 210 | 58.3 | 21.5 | 1480 | 84 | 22 | 4 | 425 |
| | 300 | 83.3 | 20 | | | | | |
| | 330 | 91.7 | 18 | | | | | |

尺寸图DIMENSION FIGURE

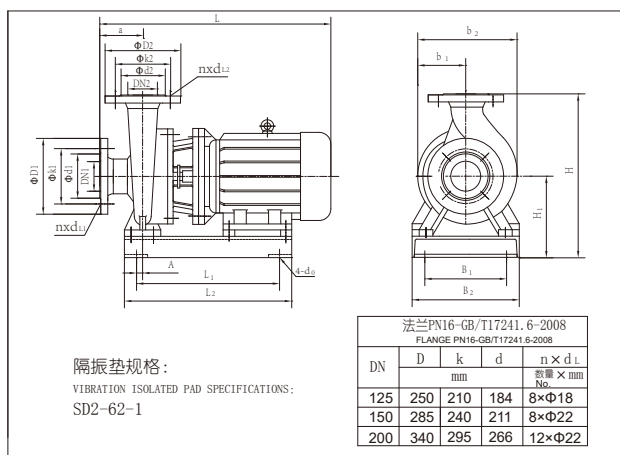

KQW尺寸表DIMENSION TABLE

| 型号 TYPE | 外形尺寸 | | | 安装尺寸 | | | | | | | DN1 | DN2 | | |
|---------------------|-------------------|-----|----------------|-----------------------|------------------|-----|----------------|----------------|----------------|----------------|-----|-----|----------------|-----|
| | Figure dimensions | | | Installing dimensions | | | | | | | | | | |
| | L | H | b ₂ | b ₁ | 4-φ ₀ | a | L ₁ | B ₁ | L ₂ | B ₂ | | | H ₁ | A |
| 150KQW173-60-55/4 | 1145 | 958 | 630 | 305 | 4-φ20 | 180 | 760 | 430 | 860 | 560 | 458 | 50 | 150 | 150 |
| 150KQW180-70-55/2 | 1080 | 958 | 550 | 275 | 4-φ20 | 125 | 800 | 430 | 900 | 560 | 383 | 30 | 150 | 125 |
| 150KQW187-70-75/4 | 1215 | 958 | 630 | 305 | 4-φ20 | 180 | 830 | 430 | 930 | 560 | 458 | 50 | 150 | 150 |
| 150KQW200-80-75/2 | 1150 | 793 | 580 | 290 | 4-φ20 | 125 | 800 | 430 | 900 | 560 | 383 | 30 | 150 | 125 |
| 150KQW200-80-75/4 | 1215 | 958 | 630 | 305 | 4-φ20 | 180 | 830 | 430 | 930 | 560 | 458 | 50 | 150 | 150 |
| 200KQW280-10-11/4 | 900 | 862 | 534 | 255 | 4-φ20 | 160 | 580 | 370 | 680 | 510 | 382 | 50 | 200 | 200 |
| 200KQW300-12.5-15/4 | 930 | 862 | 534 | 255 | 4-φ20 | 160 | 580 | 370 | 680 | 510 | 382 | 50 | 200 | 200 |
| 200KQW280-16-18.5/4 | 970 | 862 | 534 | 255 | 4-φ20 | 160 | 580 | 370 | 680 | 510 | 382 | 50 | 200 | 200 |
| 200KQW300-20-22/4 | 1020 | 862 | 529 | 250 | 4-φ20 | 160 | 615 | 370 | 715 | 510 | 382 | 50 | 200 | 200 |

性能曲线 CHARACTERISTIC CURVE

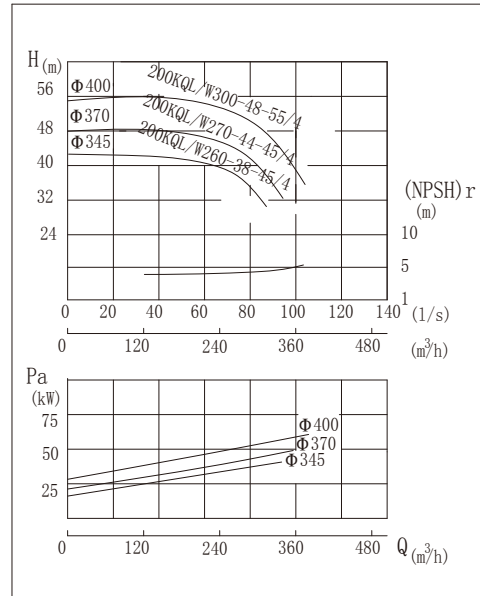
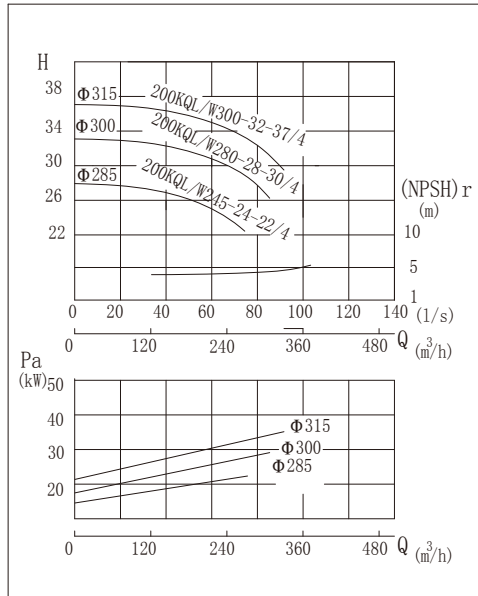

尺寸图 DIMENSION FIGURE

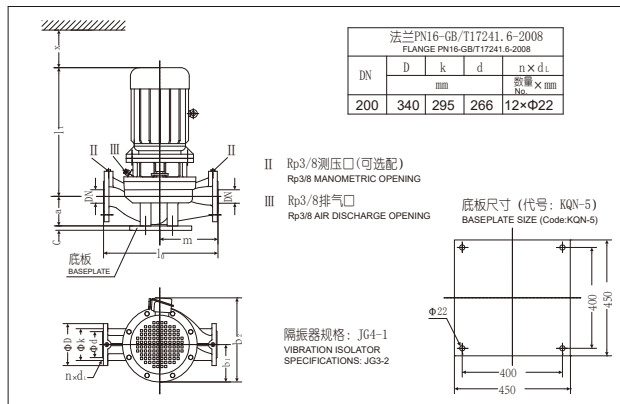

KQL尺寸表 DIMENSION TABLE

| 型号 TYPE | DN | l ₀ | m | a | c | l ₁ | b ₁ | b ₂ | x |
|--------------------|-----|----------------|-----|-----|----|----------------|----------------|----------------|-----|
| | | mm | | | | | | | |
| 200KQL245-24-22/4 | 200 | 1000 | 500 | 295 | 37 | 876 | 250 | 540 | 155 |
| 200KQL280-28-30/4 | 200 | 1000 | 500 | 295 | 37 | 876 | 270 | 610 | 155 |
| 200KQL300-32-37/4 | 200 | 1000 | 500 | 295 | 37 | 886 | 295 | 625 | 155 |
| 200KQL260-38-45/4 | 200 | 1070 | 535 | 280 | 37 | 914 | 295 | 625 | 155 |
| 200KQL270-44-45/4 | 200 | 1070 | 535 | 280 | 37 | 915 | 315 | 680 | 155 |
| 200KQL300-48-55/4 | 200 | 1070 | 535 | 280 | 37 | 976 | 360 | 760 | 155 |
| 200KQL262-60-75/4 | 200 | 1170 | 560 | 320 | 37 | 1035 | 360 | 760 | 165 |
| 200KQL280-70-90/4 | 200 | 1170 | 560 | 320 | 37 | 1096 | 360 | 760 | 165 |
| 200KQL300-80-110/4 | 200 | 1170 | 560 | 320 | 37 | 1350 | 450 | 980 | 165 |

性能曲线CHARACTERISTIC CURVE

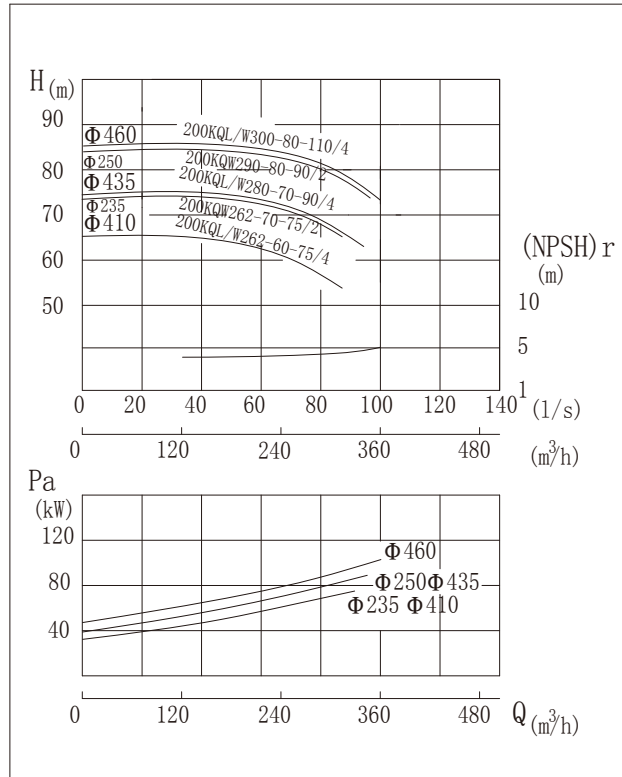

参数表PERFORMANCE DATA

| 型号 TYPE | 流量 Capacity | | 扬程 Head (m) | 转速 Speed (r/min) | 效率 Efficiency (%) | 电机 功率 Power (kW) | 必需汽蚀 余量 (NPSH)r (m) | 重量 Weight (kg) |
|----------------------|----------------|-------|-------------------|------------------------|-------------------------|---------------------------|------------------------------|----------------------|
| | (m³/h) | (l/s) | | | | | | |
| 200KQL/W245-24-22/4 | 171 | 47.5 | 25.4 | 1480 | 82 | 22 | 4 | 455 |
| | 245 | 72.2 | 24 | | | | | |
| | 270 | 75.0 | 21.6 | | | | | |
| 200KQL/W280-28-30/4 | 196 | 54.4 | 30.6 | 1480 | 82 | 30 | 4 | 520 |
| | 280 | 77.8 | 28 | | | | | |
| | 308 | 85.6 | 26.2 | | | | | |
| 200KQL/W300-32-37/4 | 210 | 58.3 | 34.5 | 1480 | 83.8 | 37 | 4 | 615 |
| | 300 | 83.3 | 32 | | | | | |
| | 330 | 91.7 | 29.5 | | | | | |
| 200KQL/W260-38-45/4 | 182 | 50.6 | 41.4 | 1480 | 78 | 45 | 4 | 575 |
| | 260 | 72.2 | 38 | | | | | |
| | 312 | 86.7 | 29.6 | | | | | |
| 200KQL/W270-44-45/4 | 189 | 52.5 | 46.2 | 1480 | 80 | 45 | 4 | 648 |
| | 270 | 75.0 | 44 | | | | | |
| | 297 | 82.5 | 39.6 | | | | | |
| 200KQL/W300-48-55/4 | 210 | 58.3 | 50.4 | 1480 | 81.6 | 55 | 4 | 745 |
| | 300 | 83.3 | 48 | | | | | |
| | 330 | 91.7 | 43.2 | | | | | |
| 200KQL/W262-60-75/4 | 182 | 50.6 | 64 | 1480 | 73 | 75 | 4.5 | 888 |
| | 262 | 72.8 | 60 | | | | | |
| | 312 | 86.7 | 54 | | | | | |
| 200KQW262-70-75/2 | 182 | 50.6 | 78 | 2960 | 78 | 75 | 8 | 790 |
| | 262 | 72.8 | 70 | | | | | |
| | 312 | 86.7 | 65 | | | | | |
| 200KQL/W280-70-90/4 | 196 | 54.4 | 74 | 1480 | 75 | 90 | 4.5 | 986 |
| | 280 | 77.8 | 70 | | | | | |
| | 336 | 93.3 | 64 | | | | | |
| 200KQW290-80-90/2 | 203 | 56.4 | 92 | 2960 | 80 | 90 | 8 | 850 |
| | 290 | 80.6 | 80 | | | | | |
| | 348 | 96.7 | 69 | | | | | |
| 200KQL/W300-80-110/4 | 210 | 58.3 | 85 | 1480 | 76 | 110 | 4.5 | 1308 |
| | 300 | 83.3 | 80 | | | | | |
| | 360 | 100.0 | 73 | | | | | |

尺寸图DIMENSION FIGURE

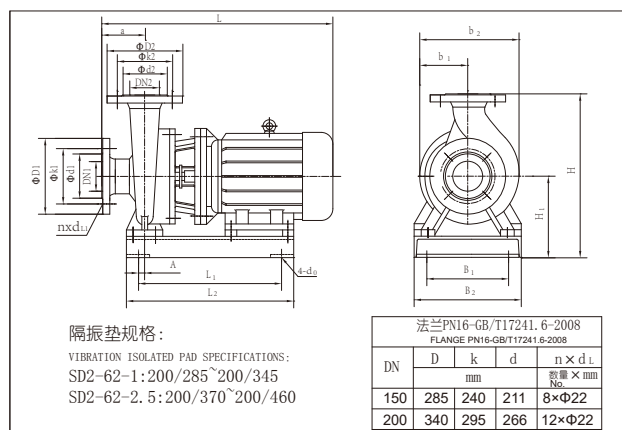

KQW尺寸表DIMENSION TABLE

| 型号 TYPE | 外形尺寸 | | 安装尺寸 | | | | | | | | | | DN1 | DN2 |
|--------------------|-------------------|------|-----------------------|----------------|------------------|-----|----------------|----------------|----------------|----------------|----------------|----|-----|-----|
| | Figure dimensions | | Installing dimensions | | | | | | | | | | | |
| | L | H | b ₂ | b ₁ | 4-d ₀ | a | L ₁ | B ₁ | L ₂ | B ₂ | H ₁ | A | | |
| 200KQW245-24-22/4 | 1030 | 918 | 529 | 250 | 4-Φ20 | 160 | 670 | 430 | 770 | 560 | 418 | 50 | 200 | 200 |
| 200KQW280-28-30/4 | 1030 | 918 | 590 | 280 | 4-Φ20 | 160 | 670 | 430 | 770 | 560 | 418 | 50 | 200 | 200 |
| 200KQW300-32-37/4 | 1040 | 918 | 590 | 280 | 4-Φ20 | 160 | 670 | 430 | 770 | 560 | 418 | 50 | 200 | 200 |
| 200KQW260-38-45/4 | 1065 | 876 | 577 | 280 | 4-Φ20 | 160 | 695 | 430 | 795 | 560 | 418 | 50 | 200 | 200 |
| 200KQW270-44-45/4 | 1065 | 876 | 577 | 280 | 4-Φ20 | 160 | 695 | 430 | 795 | 560 | 418 | 50 | 200 | 200 |
| 200KQW300-48-55/4 | 1125 | 876 | 572 | 280 | 4-Φ20 | 160 | 760 | 430 | 860 | 560 | 418 | 50 | 200 | 200 |
| 200KQW262-60-75/4 | 1225 | 1022 | 673 | 320 | 4-Φ25 | 180 | 830 | 480 | 930 | 640 | 462 | 50 | 200 | 200 |
| 200KQW262-70-75/2 | 1195 | 855 | 580 | 290 | 4-Φ20 | 170 | 790 | 430 | 919 | 560 | 445 | 30 | 200 | 150 |
| 200KQW280-70-90/4 | 1265 | 1022 | 673 | 320 | 4-Φ25 | 180 | 880 | 480 | 980 | 640 | 462 | 50 | 200 | 200 |
| 200KQW290-80-90/2 | 1245 | 855 | 580 | 290 | 4-Φ20 | 170 | 840 | 430 | 970 | 560 | 445 | 30 | 200 | 150 |
| 200KQW300-80-110/4 | 1530 | 1022 | 683 | 330 | 4-Φ25 | 180 | 955 | 480 | 1055 | 640 | 462 | 50 | 200 | 200 |

性能曲线 CHARACTERISTIC CURVE

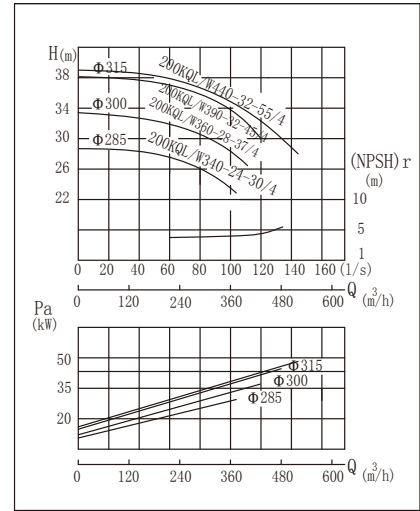
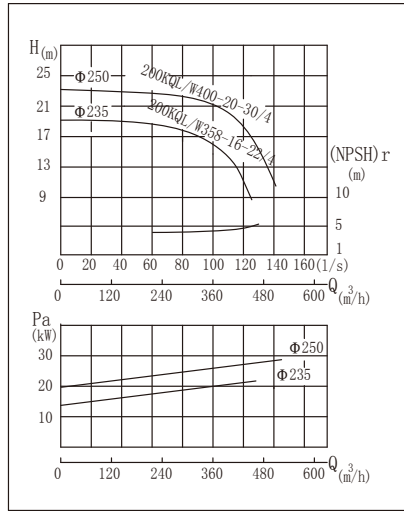
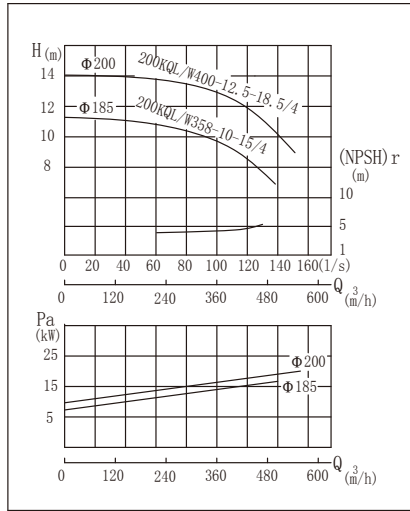

尺寸图 DIMENSION FIGURE

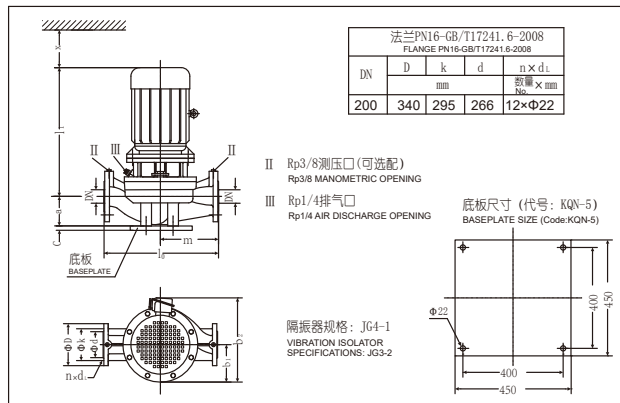

KQL尺寸表 DIMENSION TABLE

| 型号 TYPE | DN | l ₀ | m | a | c | l ₁ | b ₁ | b ₂ | x |
|-----------------------|-----|----------------|-----|-----|----|----------------|----------------|----------------|-----|
| | | mm | | | | | | | |
| 200KQL358-10-15/4 | 200 | 990 | 480 | 275 | 37 | 781 | 250 | 530 | 150 |
| 200KQL400-12.5-18.5/4 | 200 | 990 | 480 | 275 | 37 | 823 | 250 | 530 | 150 |
| 200KQL358-16-22/4 | 200 | 990 | 480 | 275 | 37 | 873 | 250 | 530 | 150 |
| 200KQL400-20-30/4 | 200 | 990 | 480 | 275 | 37 | 873 | 270 | 575 | 150 |
| 200KQL340-24-30/4 | 200 | 1000 | 500 | 295 | 37 | 876 | 270 | 575 | 155 |
| 200KQL360-28-37/4 | 200 | 1000 | 500 | 295 | 37 | 886 | 295 | 625 | 155 |
| 200KQL390-32-45/4 | 200 | 1000 | 500 | 295 | 37 | 911 | 295 | 625 | 155 |
| 200KQL440-32-55/4 | 200 | 1000 | 500 | 295 | 37 | 985 | 315 | 680 | 155 |
| 200KQL340-36-45/4 | 200 | 1070 | 535 | 280 | 37 | 914 | 295 | 625 | 155 |
| 200KQL370-40-55/4 | 200 | 1070 | 535 | 280 | 37 | 976 | 315 | 680 | 155 |
| 200KQL374-44-75/4 | 200 | 1070 | 535 | 280 | 37 | 1035 | 360 | 760 | 155 |
| 200KQL400-50-75/4 | 200 | 1070 | 535 | 280 | 37 | 1035 | 360 | 760 | 155 |

性能曲线CHARACTERISTIC CURVE

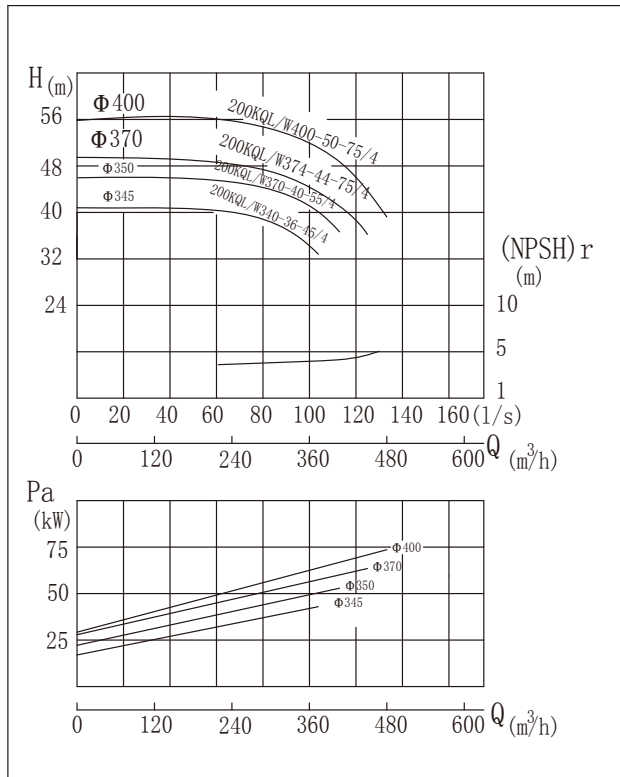

参数表PERFORMANCE DATA

| 型号 TYPE | 流量 Capacity | | 扬程 Head (m) | 转速 Speed (r/min) | 效率 Efficiency (%) | 电机 功率 Power (kW) | 必需汽蚀 余量 (NPSH) _r (m) | 重量 Weight (kg) |
|-------------------------|----------------|-------|-------------------|------------------------|-------------------------|---------------------------|--|----------------------|
| | (m³/h) | (l/s) | | | | | | |
| 200KQL/W358-10-15/4 | 250 | 69.4 | 13 | 1480 | 81 | 15 | 4 | 346 |
| | 358 | 99.4 | 10 | | | | | |
| | 394 | 109.4 | 7 | | | | | |
| 200KQL/W400-12.5-18.5/4 | 280 | 77.8 | 15.5 | 1480 | 82 | 18.5 | 4 | 380 |
| | 400 | 111.1 | 12.5 | | | | | |
| | 440 | 122.2 | 10.2 | | | | | |
| 200KQL/W358-16-22/4 | 250 | 69.4 | 18 | 1480 | 83 | 22 | 4 | 586 |
| | 358 | 99.4 | 16 | | | | | |
| | 430 | 119.4 | 11.2 | | | | | |
| 200KQL/W400-20-30/4 | 280 | 77.8 | 23 | 1480 | 84 | 30 | 4 | 454 |
| | 400 | 111.1 | 20 | | | | | |
| | 480 | 133.3 | 14 | | | | | |
| 200KQL/W340-24-30/4 | 238 | 66.1 | 25.2 | 1480 | 80 | 30 | 4 | 510 |
| | 340 | 96.1 | 24 | | | | | |
| | 374 | 103.9 | 21.6 | | | | | |
| 200KQL/W360-28-37/4 | 252 | 70.0 | 31.5 | 1480 | 81 | 37 | 4 | 560 |
| | 360 | 100.0 | 28 | | | | | |
| | 396 | 110.0 | 25 | | | | | |
| 200KQL/W390-32-45/4 | 273 | 75.8 | 34.5 | 1480 | 83.9 | 45 | 4 | 600 |
| | 390 | 108.3 | 32 | | | | | |
| | 429 | 119.2 | 28.8 | | | | | |
| 200KQL/W440-32-55/4 | 308 | 85.6 | 37 | 1480 | 82 | 55 | 4.5 | 708 |
| | 440 | 122.2 | 32 | | | | | |
| | 520 | 144.4 | 28 | | | | | |
| 200KQL/W340-36-45/4 | 238 | 66.1 | 39 | 1480 | 80 | 45 | 4 | 605 |
| | 340 | 96.1 | 36 | | | | | |
| | 374 | 103.9 | 32.4 | | | | | |
| 200KQL/W370-40-55/4 | 259 | 71.9 | 45.5 | 1480 | 82 | 55 | 4 | 712 |
| | 370 | 102.8 | 40 | | | | | |
| | 407 | 113.1 | 36 | | | | | |
| 200KQL/W374-44-75/4 | 262 | 72.8 | 48 | 1480 | 81 | 75 | 4 | 828 |
| | 374 | 103.9 | 44 | | | | | |
| | 449 | 124.7 | 34 | | | | | |
| 200KQL/W400-50-75/4 | 280 | 77.8 | 54.5 | 1480 | 82.6 | 75 | 4 | 819 |
| | 400 | 111.1 | 50 | | | | | |
| | 480 | 133.3 | 39 | | | | | |

尺寸图DIMENSION FIGURE

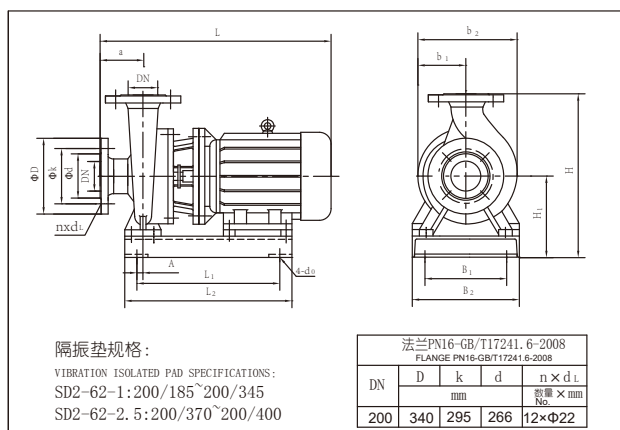

KQW尺寸表DIMENSION TABLE

| 型号 TYPE | 外形尺寸 | | | | 安装尺寸 | | | | | | | DN | |
|-----------------------|-------------------|-----|----------------|----------------|-----------------------|-----|----------------|----------------|----------------|----------------|----------------|----|-----|
| | Figure dimensions | | | | Installing dimensions | | | | | | | | |
| | L | H | b ₂ | b ₁ | 4-φ _{d0} | a | L ₁ | B ₁ | L ₂ | B ₂ | H ₁ | | A |
| 200KQW358-10-15/4 | 930 | 862 | 529 | 250 | 4-φ20 | 160 | 580 | 370 | 680 | 510 | 382 | 50 | 200 |
| 200KQW400-12.5-18.5/4 | 970 | 862 | 529 | 250 | 4-φ20 | 160 | 580 | 370 | 680 | 510 | 382 | 50 | 200 |
| 200KQW358-16-22/4 | 1020 | 862 | 529 | 250 | 4-φ20 | 160 | 615 | 370 | 715 | 510 | 382 | 50 | 200 |
| 200KQW400-20-30/4 | 1030 | 859 | 529 | 250 | 4-φ20 | 160 | 665 | 370 | 765 | 500 | 379 | 50 | 200 |
| 200KQW340-24-30/4 | 1030 | 918 | 572 | 280 | 4-φ20 | 160 | 670 | 430 | 770 | 560 | 418 | 50 | 200 |
| 200KQW360-28-37/4 | 1040 | 918 | 572 | 280 | 4-φ20 | 160 | 670 | 430 | 770 | 560 | 418 | 50 | 200 |
| 200KQW390-32-45/4 | 1065 | 918 | 572 | 280 | 4-φ20 | 160 | 695 | 430 | 795 | 560 | 418 | 50 | 200 |
| 200KQW440-32-55/4 | 1120 | 918 | 572 | 280 | 4-φ20 | 160 | 760 | 430 | 860 | 560 | 418 | 50 | 200 |
| 200KQW340-36-45/4 | 1065 | 878 | 572 | 280 | 4-φ20 | 160 | 695 | 430 | 795 | 560 | 418 | 50 | 200 |
| 200KQW370-40-55/4 | 1125 | 878 | 572 | 280 | 4-φ20 | 160 | 760 | 430 | 860 | 560 | 418 | 50 | 200 |
| 200KQW374-44-75/4 | 1205 | 878 | 587 | 290 | 4-φ20 | 160 | 830 | 430 | 930 | 560 | 418 | 50 | 200 |
| 200KQW400-50-75/4 | 1205 | 878 | 587 | 290 | 4-φ20 | 160 | 830 | 430 | 930 | 560 | 418 | 50 | 200 |

性能曲线 CHARACTERISTIC CURVE

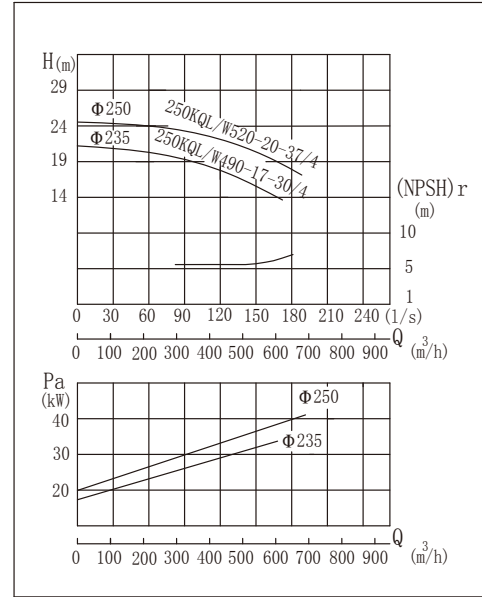
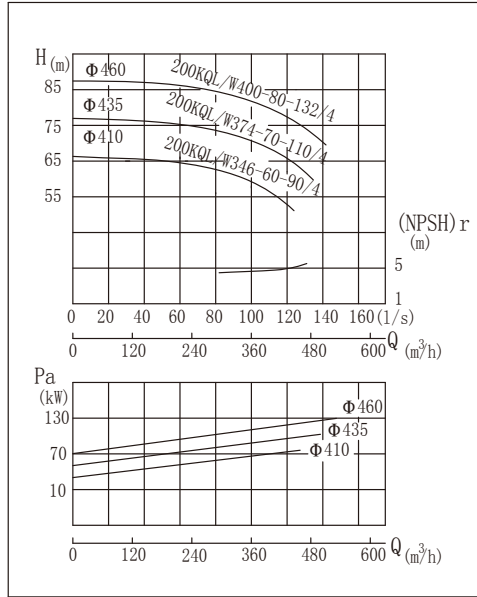

尺寸图 DIMENSION FIGURE

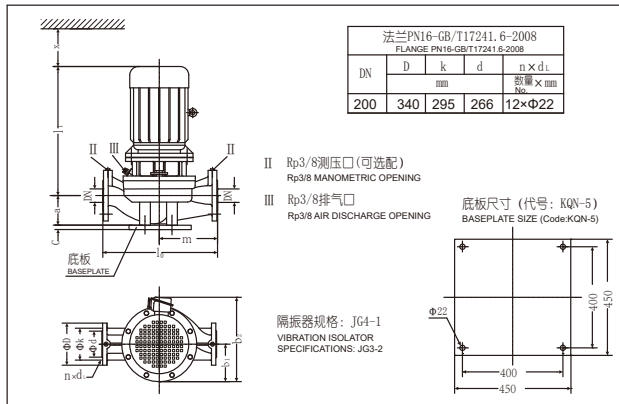

KQL尺寸表 DIMENSION TABLE

| 型号 TYPE | DN | l ₀ | m | a | c | l ₁ | b ₁ | b ₂ | x |
|--------------------|-----|----------------|-----|-----|----|----------------|----------------|----------------|-----|
| | | mm | | | | | | | |
| 200KQL346-60-90/4 | 200 | 1170 | 560 | 320 | 37 | 1096 | 360 | 760 | 165 |
| 200KQL374-70-110/4 | 200 | 1170 | 560 | 320 | 37 | 1350 | 450 | 980 | 165 |
| 200KQL400-80-132/4 | 200 | 1170 | 560 | 320 | 37 | 1371 | 450 | 980 | 165 |

尺寸图 DIMENSION FIGURE

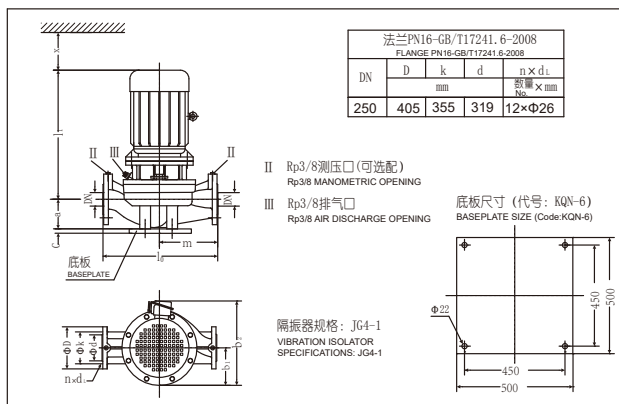

KQL尺寸表 DIMENSION TABLE

| 型号 TYPE | DN | l ₀ | m | a | c | l ₁ | b ₁ | b ₂ | x |
|-------------------|-----|----------------|-----|-----|----|----------------|----------------|----------------|-----|
| | | mm | | | | | | | |
| 250KQL490-17-30/4 | 250 | 1100 | 550 | 335 | 40 | 864 | 295 | 660 | 180 |
| 250KQL520-20-37/4 | 250 | 1100 | 550 | 335 | 40 | 870 | 295 | 660 | 180 |
| 250KQL500-25-45/4 | 250 | 1100 | 550 | 335 | 40 | 915 | 295 | 660 | 180 |
| 250KQL500-28-55/4 | 250 | 1100 | 550 | 335 | 40 | 959 | 360 | 660 | 180 |
| 250KQL550-32-75/4 | 250 | 1100 | 550 | 335 | 40 | 1039 | 360 | 760 | 180 |

性能曲线CHARACTERISTIC CURVE

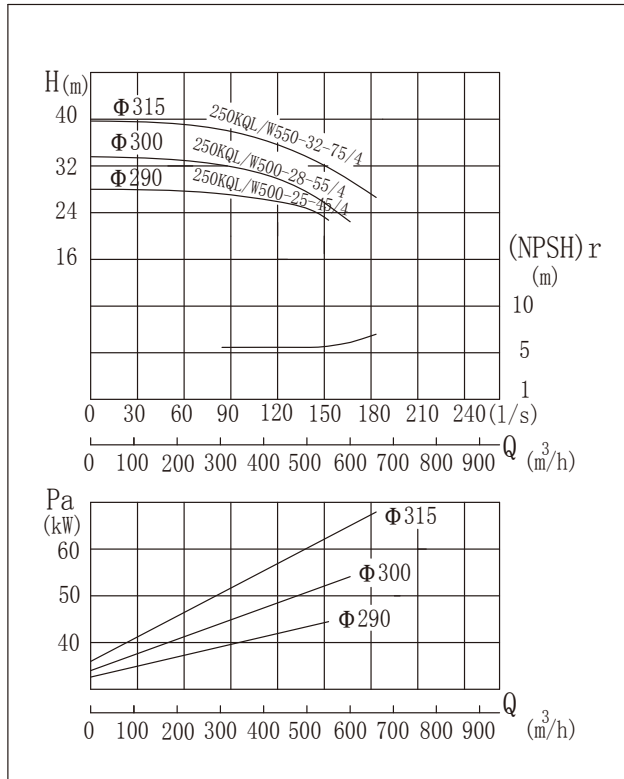

参数表PERFORMANCE DATA

| 型号 TYPE | 流量 Capacity | | 扬程 Head (m) | 转速 Speed (r/min) | 效率 Efficiency (%) | 电机 功率 Power (kW) | 必需汽蚀 余量 (NPSH) _r (m) | 重量 Weight (kg) |
|----------------------|----------------|-------|-------------------|------------------------|-------------------------|---------------------------|--|----------------------|
| | (m³/h) | (l/s) | | | | | | |
| 200KQL/W346-60-90/4 | 242 | 67.2 | 64 | 1480 | 75 | 90 | 4.5 | 935 |
| | 346 | 96.1 | 60 | | | | | |
| | 415 | 115.3 | 54 | | | | | |
| 200KQL/W374-70-110/4 | 262 | 72.8 | 74 | 1480 | 77 | 110 | 4.5 | 1276 |
| | 374 | 103.9 | 70 | | | | | |
| | 449 | 124.7 | 64 | | | | | |
| 200KQL/W400-80-132/4 | 280 | 77.8 | 85 | 1480 | 78.5 | 132 | 4.5 | 1380 |
| | 400 | 111.1 | 80 | | | | | |
| | 480 | 133.3 | 73 | | | | | |
| 250KQL/W490-17-30/4 | 343 | 95.3 | 19 | 1480 | 83.5 | 30 | 5.5 | 545 |
| | 490 | 136.1 | 17 | | | | | |
| | 539 | 149.7 | 15.3 | | | | | |
| 250KQL/W520-20-37/4 | 364 | 101.1 | 22 | 1480 | 84.5 | 37 | 5.5 | 630 |
| | 520 | 144.4 | 20 | | | | | |
| | 600 | 166.7 | 17 | | | | | |
| 250KQL/W500-25-45/4 | 350 | 97.2 | 26.2 | 1480 | 84.7 | 45 | 5.5 | 622 |
| | 500 | 138.9 | 25 | | | | | |
| | 600 | 166.7 | 21 | | | | | |
| 250KQL/W500-28-55/4 | 364 | 101.1 | 31.5 | 1480 | 83 | 55 | 5.5 | 716 |
| | 500 | 138.9 | 28 | | | | | |
| | 600 | 166.7 | 25 | | | | | |
| 250KQL/W550-32-75/4 | 400 | 111.1 | 33.5 | 1480 | 85 | 75 | 5.5 | 852 |
| | 550 | 152.8 | 32 | | | | | |
| | 660 | 183.3 | 29 | | | | | |

尺寸图DIMENSION FIGURE

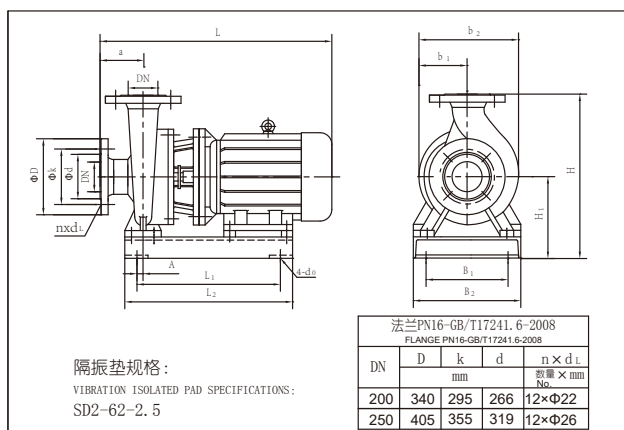

KQW尺寸表DIMENSION TABLE

| 型号 TYPE | 外形尺寸 Figure dimensions | | | | 安装尺寸 Installing dimensions | | | | | | | | DN |
|--------------------|---------------------------|------|----------------|----------------|-------------------------------|-----|----------------|----------------|----------------|----------------|----------------|----|-----|
| | L | H | b ₂ | b ₁ | 4-d ₀ | a | L ₁ | B ₁ | L ₂ | B ₂ | H ₁ | A | |
| 200KQW346-60-90/4 | 1265 | 1022 | 661 | 320 | 4-φ25 | 180 | 880 | 480 | 980 | 640 | 462 | 50 | 200 |
| 200KQW374-70-110/4 | 1530 | 1022 | 683 | 330 | 4-φ25 | 180 | 955 | 480 | 1055 | 640 | 462 | 50 | 200 |
| 200KQW400-80-132/4 | 1560 | 1022 | 683 | 330 | 4-φ25 | 180 | 1005 | 480 | 1150 | 640 | 462 | 50 | 200 |
| 250KQW490-17-30/4 | 1074 | 989 | 690 | 300 | 4-φ20 | 200 | 630 | 500 | 795 | 640 | 441 | 30 | 250 |
| 250KQW520-20-37/4 | 1084 | 989 | 690 | 300 | 4-φ20 | 200 | 630 | 500 | 780 | 640 | 439 | 30 | 250 |
| 250KQW500-25-45/4 | 1109 | 989 | 690 | 320 | 4-φ20 | 200 | 630 | 500 | 805 | 640 | 439 | 30 | 250 |
| 250KQW500-28-55/4 | 1169 | 989 | 660 | 320 | 4-φ20 | 200 | 630 | 500 | 880 | 640 | 439 | 30 | 250 |
| 250KQW550-32-75/4 | 1245 | 989 | 660 | 320 | 4-φ20 | 200 | 710 | 500 | 935 | 640 | 439 | 30 | 250 |

性能曲线 CHARACTERISTIC CURVE

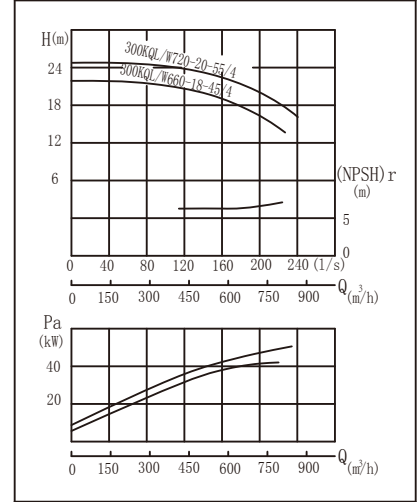
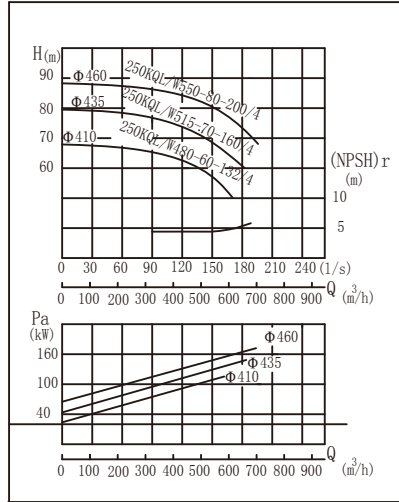
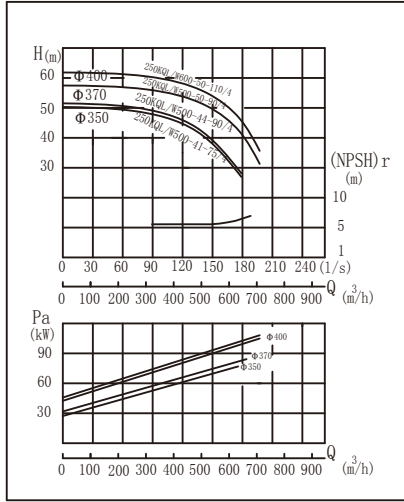

尺寸图 DIMENSION FIGURE

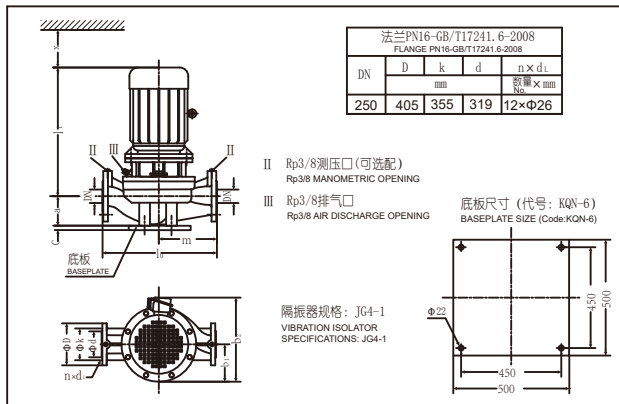

KQL 尺寸表 DIMENSION TABLE

| 型号 TYPE | DN | l_0 | m | a | c | l_1 | b_1 | b_2 | x |
|--------------------|-----|-------|-----|-----|-----|-------|-------|-------|-----|
| | | mm | | | | | | | |
| 250KQL500-41-75/4 | 250 | 1200 | 600 | 335 | 40 | 1035 | 360 | 760 | 205 |
| 250KQL500-44-90/4 | 250 | 1200 | 600 | 335 | 40 | 1085 | 360 | 760 | 205 |
| 250KQL500-50-90/4 | 250 | 1200 | 600 | 335 | 40 | 1085 | 360 | 760 | 205 |
| 250KQL600-50-110/4 | 250 | 1200 | 600 | 335 | 40 | 1360 | 450 | 980 | 205 |
| 250KQL480-60-132/4 | 250 | 1360 | 650 | 380 | 40 | 1396 | 450 | 880 | 205 |
| 250KQL515-70-160/4 | 250 | 1360 | 650 | 380 | 40 | 1380 | 450 | 880 | 205 |
| 250KQL550-80-200/4 | 250 | 1360 | 650 | 380 | 40 | 1380 | 450 | 880 | 205 |

尺寸图 DIMENSION FIGURE

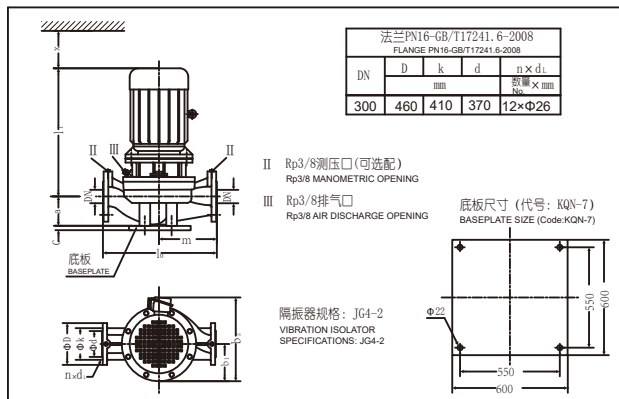

KQL 尺寸表 DIMENSION TABLE

| 型号 TYPE | DN | l_0 | m | a | c | l_1 | b_1 | b_2 | x |
|-------------------|-----|-------|-----|-----|-----|-------|-------|-------|-----|
| | | mm | | | | | | | |
| 300KQL660-18-45/4 | 300 | 1250 | 625 | 390 | 45 | 937 | 305 | 710 | 230 |
| 300KQL720-20-55/4 | 300 | 1250 | 625 | 390 | 45 | 1001 | 325 | 725 | 230 |
| 300KQL600-24-55/4 | 300 | 1250 | 625 | 390 | 45 | 1001 | 325 | 725 | 230 |
| 300KQL660-28-75/4 | 300 | 1250 | 625 | 390 | 45 | 1077 | 360 | 760 | 230 |
| 300KQL720-32-90/4 | 300 | 1250 | 625 | 390 | 45 | 1115 | 360 | 760 | 230 |

性能曲线CHARACTERISTIC CURVE

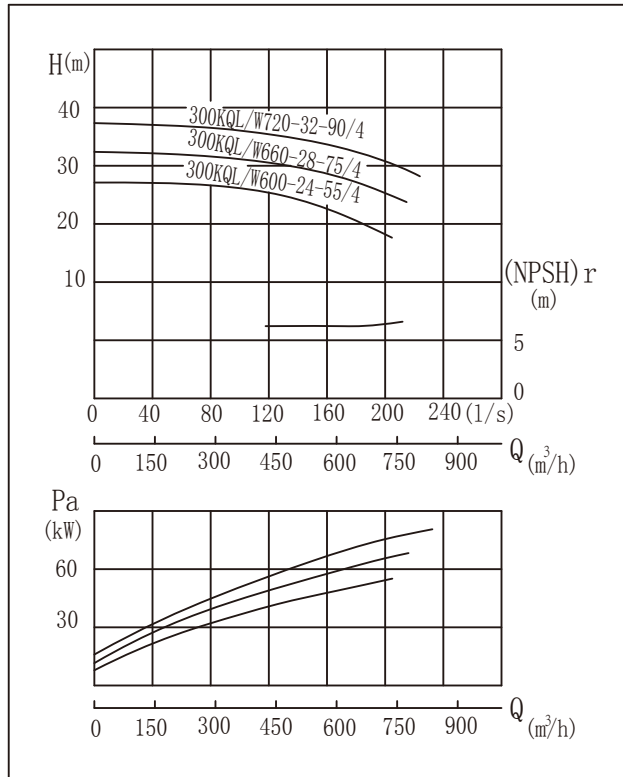

参数表PERFORMANCE DATA

| 型号 TYPE | 流量 Capacity | | 扬程 Head (m) | 转速 Speed (r/min) | 效率 Efficiency (%) | 电机 功率 Power (kW) | 必需汽蚀 余量 (NPSH)r (m) | 重量 Weight (kg) |
|----------------------|----------------|-------|-------------------|------------------------|-------------------------|---------------------------|------------------------------|----------------------|
| | (m³/h) | (l/s) | | | | | | |
| 250KQL/W500-41-75/4 | 350 | 97.2 | 44 | 1480 | 83 | 75 | 5.5 | 930 |
| | 500 | 138.9 | 41 | | | | | |
| | 550 | 152.8 | 36.9 | | | | | |
| 250KQL/W500-44-90/4 | 365 | 101.4 | 47 | 1480 | 80 | 90 | 5.5 | 970 |
| | 500 | 138.9 | 44 | | | | | |
| | 600 | 166.7 | 35 | | | | | |
| 250KQL/W500-50-90/4 | 350 | 97.2 | 52.5 | 1480 | 84.1 | 90 | 5.5 | 1035 |
| | 500 | 138.9 | 50 | | | | | |
| | 550 | 152.8 | 45 | | | | | |
| 250KQL/W600-50-110/4 | 420 | 116.7 | 54.5 | 1480 | 83 | 110 | 6.0 | 1450 |
| | 600 | 166.7 | 50 | | | | | |
| | 720 | 200.0 | 42 | | | | | |
| 250KQL/W480-60-132/4 | 350 | 97.2 | 64 | 1480 | 79 | 132 | 4.5 | 1492 |
| | 480 | 133.3 | 60 | | | | | |
| | 580 | 161.1 | 52.5 | | | | | |
| 250KQL/W515-70-160/4 | 375 | 104.2 | 74 | 1480 | 80 | 160 | 4.5 | 1510 |
| | 515 | 143.0 | 70 | | | | | |
| | 620 | 172.2 | 61.2 | | | | | |
| 250KQL/W550-80-200/4 | 400 | 111.1 | 85 | 1480 | 81.6 | 200 | 4.5 | 1697 |
| | 550 | 152.8 | 80 | | | | | |
| | 660 | 183.3 | 73 | | | | | |
| 300KQL/W660-18-45/4 | 460 | 127.8 | 20 | 1480 | 82 | 45 | 6.0 | 710 |
| | 660 | 183.3 | 17.5 | | | | | |
| | 790 | 219.4 | 14 | | | | | |
| 300KQL/W720-20-55/4 | 500 | 138.9 | 23 | 1480 | 84.2 | 55 | 6.0 | 820 |
| | 720 | 200.0 | 20 | | | | | |
| | 860 | 239.0 | 16 | | | | | |
| 300KQL/W600-24-55/4 | 420 | 116.7 | 26.5 | 1480 | 81 | 55 | 6.0 | 805 |
| | 600 | 166.7 | 24 | | | | | |
| | 720 | 200.0 | 20.6 | | | | | |
| 300KQL/W660-28-75/4 | 460 | 127.8 | 30.5 | 1480 | 83 | 75 | 6.0 | 938 |
| | 660 | 183.3 | 28 | | | | | |
| | 790 | 219.4 | 24 | | | | | |
| 300KQL/W720-32-90/4 | 500 | 138.9 | 35 | 1480 | 85.8 | 90 | 6.0 | 1043 |
| | 720 | 200.0 | 32 | | | | | |
| | 860 | 239.0 | 28 | | | | | |

尺寸图DIMENSION FIGURE

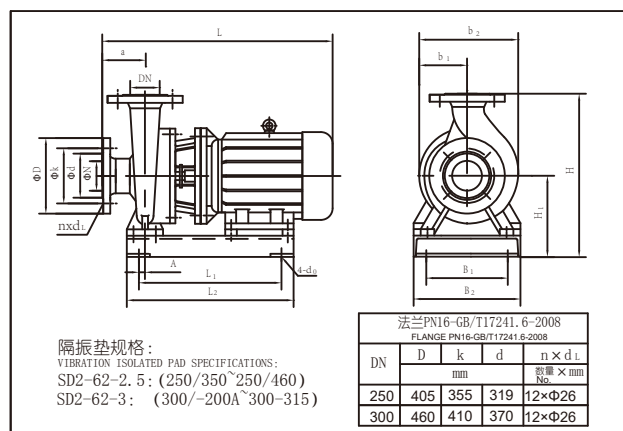

KQW尺寸表DIMENSION TABLE

| 型号 TYPE | 外形尺寸 Figure dimensions | | | | 安装尺寸 Installing dimensions | | | | | | | | DN |
|--------------------|---------------------------|------|----------------|----------------|-------------------------------|-----|----------------|----------------|----------------|----------------|----------------|-----|-----|
| | L | H | b ₂ | b ₁ | 4-φ _{d0} | a | L ₁ | B ₁ | L ₂ | B ₂ | H ₁ | A | |
| 250KQW500-41-75/4 | 1245 | 1039 | 690 | 300 | 4-φ20 | 200 | 710 | 500 | 935 | 640 | 464 | 30 | 250 |
| 250KQW500-44-90/4 | 1285 | 1039 | 690 | 300 | 4-φ20 | 200 | 710 | 500 | 985 | 640 | 464 | 30 | 250 |
| 250KQW500-50-90/4 | 1285 | 1039 | 690 | 330 | 4-φ20 | 200 | 710 | 500 | 985 | 640 | 464 | 30 | 250 |
| 250KQW600-50-110/4 | 1530 | 1039 | 700 | 330 | 4-φ25 | 200 | 800 | 508 | 1060 | 640 | 464 | 30 | 250 |
| 250KQW480-60-132/4 | 1600 | 1144 | 731 | 341 | 4-φ25 | 220 | 900 | 550 | 1170 | 640 | 494 | 30 | 250 |
| 250KQW515-70-160/4 | 1600 | 1144 | 731 | 341 | 4-φ25 | 220 | 900 | 550 | 1170 | 640 | 494 | 30 | 250 |
| 250KQW550-80-200/4 | 1600 | 1144 | 731 | 341 | 4-φ25 | 220 | 900 | 550 | 1170 | 640 | 494 | 30 | 250 |
| 300KQW660-18-45/4 | 1178 | 1081 | 695 | 300 | 4-φ25 | 253 | 710 | 430 | 930 | 560 | 484 | 110 | 300 |
| 300KQW720-20-55/4 | 1238 | 1081 | 695 | 300 | 4-φ25 | 253 | 780 | 430 | 975 | 640 | 484 | 110 | 300 |
| 300KQW600-24-55/4 | 1238 | 1081 | 695 | 300 | 4-φ25 | 253 | 780 | 430 | 1000 | 640 | 481 | 110 | 300 |
| 300KQW660-28-75/4 | 1318 | 1081 | 695 | 300 | 4-φ25 | 253 | 850 | 430 | 1015 | 640 | 481 | 110 | 300 |
| 300KQW720-32-90/4 | 1358 | 1081 | 720 | 300 | 4-φ25 | 253 | 890 | 430 | 1065 | 640 | 481 | 110 | 300 |

性能曲线CHARACTERISTIC CURVE

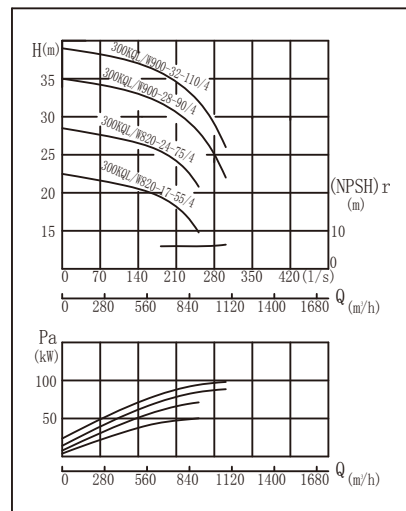
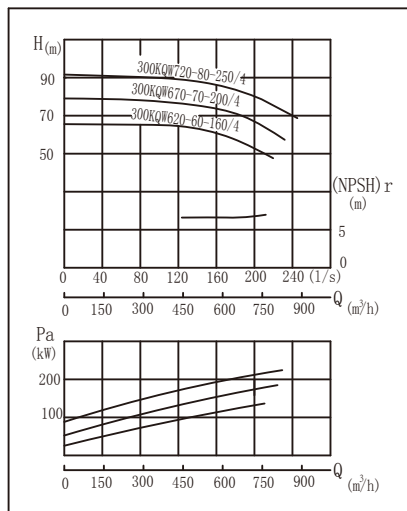
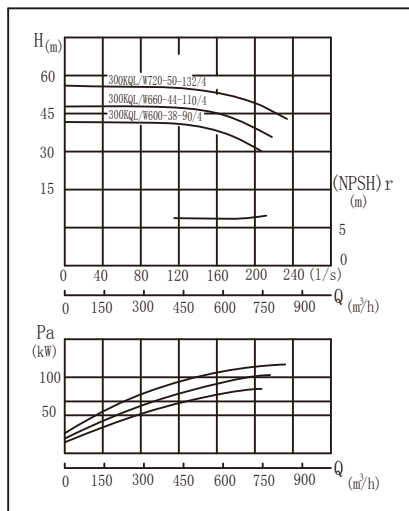

尺寸图DIMENSION FIGURE

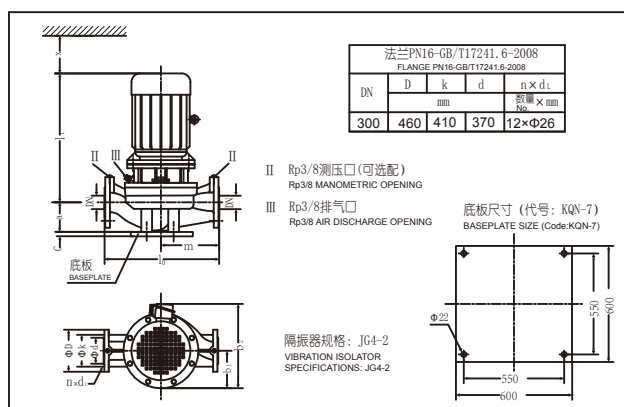

KQL尺寸表DIMENSION TABLE

| 型号 TYPE | DN | mm | | | | | | | |
|--------------------|-----|----------------|-----|-----|----|----------------|----------------|----------------|-----|
| | | l ₀ | m | a | c | l ₁ | b ₁ | b ₂ | x |
| 300KQL600-38-90/4 | 300 | 1300 | 650 | 400 | 45 | 1095 | 385 | 835 | 230 |
| 300KQL660-44-110/4 | 300 | 1300 | 650 | 400 | 45 | 1350 | 450 | 980 | 230 |
| 300KQL720-50-132/4 | 300 | 1300 | 650 | 400 | 45 | 1380 | 450 | 980 | 230 |
| 300KQL820-17-55/4 | 300 | 1250 | 625 | 390 | 45 | 975 | 326 | 736 | 230 |
| 300KQL820-24-75/4 | 300 | 1250 | 625 | 390 | 45 | 1077 | 360 | 760 | 230 |
| 300KQL900-28-90/4 | 300 | 1250 | 625 | 390 | 45 | 1095 | 326 | 736 | 230 |
| 300KQL900-32-110/4 | 300 | 1250 | 625 | 390 | 45 | 1350 | 326 | 856 | 230 |

性能曲线CHARACTERISTIC CURVE

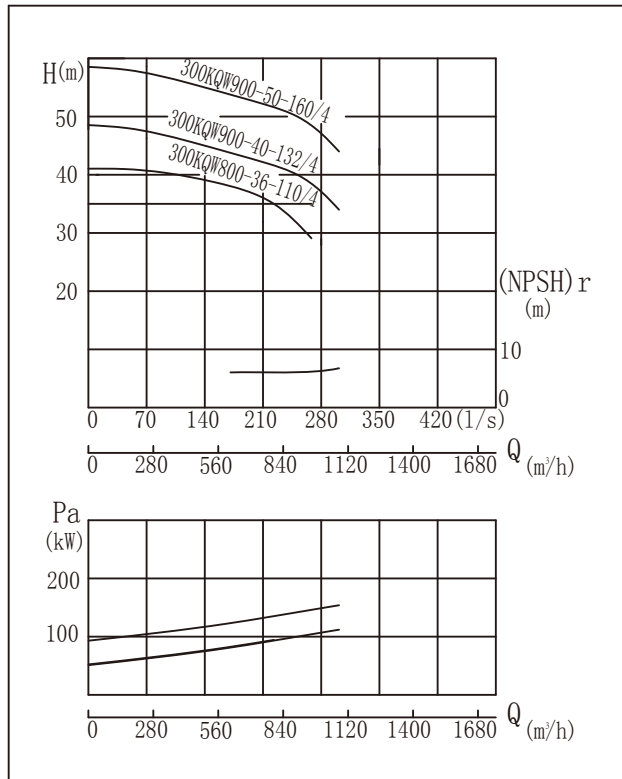

参数表PERFORMANCE DATA

| 型号 TYPE | 流量 Capacity | | 扬程 Head (m) | 转速 Speed (r/min) | 效率 Efficiency (%) | 电机 功率 Power (kW) | 必需汽蚀 余量 (NPSH)r (m) | 重量 Weight (kg) |
|----------------------|----------------|-------|-------------------|------------------------|-------------------------|---------------------------|------------------------------|----------------------|
| | (m³/h) | (l/s) | | | | | | |
| 300KQL/W600-38-90/4 | 420 | 116.7 | 42 | 1480 | 81 | 90 | 6.0 | 1160 |
| | 600 | 166.7 | 38 | | | | | |
| | 720 | 200 | 34 | | | | | |
| 300KQL/W660-44-110/4 | 460 | 127.8 | 49 | 1480 | 83 | 110 | 6.0 | 1450 |
| | 660 | 183.3 | 44 | | | | | |
| | 790 | 219.4 | 37 | | | | | |
| 300KQL/W720-50-132/4 | 500 | 138.9 | 55 | 1480 | 85.8 | 132 | 6.0 | 1650 |
| | 720 | 200 | 50 | | | | | |
| | 860 | 239 | 42 | | | | | |
| 300KQW620-60-160/4 | 430 | 119.4 | 64.5 | 1480 | 79 | 160 | 6.5 | 1720 |
| | 620 | 172.2 | 60 | | | | | |
| | 740 | 205.6 | 54 | | | | | |
| 300KQW670-70-200/4 | 465 | 129.2 | 75 | 1480 | 81 | 200 | 6.5 | 1757 |
| | 670 | 186.1 | 70 | | | | | |
| | 800 | 222.2 | 60.4 | | | | | |
| 300KQW720-80-250/4 | 500 | 138.9 | 86 | 1480 | 83.8 | 250 | 6.5 | 2342 |
| | 720 | 200.0 | 80 | | | | | |
| | 860 | 239.0 | 69 | | | | | |
| 300KQL/W820-17-55/4 | 574 | 159.0 | 20 | 1480 | 79 | 55 | 6.0 | 886 |
| | 820 | 227.8 | 17 | | | | | |
| | 984 | 273.3 | 13 | | | | | |
| 300KQL/W820-24-75/4 | 574 | 159 | 26.5 | 1480 | 80 | 75 | 6.0 | 1015 |
| | 820 | 228 | 24 | | | | | |
| | 900 | 250 | 22 | | | | | |
| 300KQL/W900-28-90/4 | 630 | 175 | 33 | 1480 | 83 | 90 | 6.0 | 1180 |
| | 900 | 250 | 28 | | | | | |
| | 1080 | 300 | 22 | | | | | |
| 300KQL/W900-32-110/4 | 630 | 175 | 36 | 1480 | 85 | 110 | 6.0 | 1500 |
| | 900 | 250 | 32 | | | | | |
| | 1080 | 300 | 27 | | | | | |
| 300KQW800-36-110/4 | 560 | 155.6 | 42 | 1480 | 83 | 110 | 6 | 1480 |
| | 800 | 222.2 | 36 | | | | | |
| | 960 | 266.7 | 29 | | | | | |
| 300KQW900-40-132/4 | 630 | 175 | 46 | 1480 | 84.5 | 132 | 6 | 1585 |
| | 900 | 250 | 40 | | | | | |
| | 1080 | 300 | 34 | | | | | |
| 300KQW900-50-160/4 | 630 | 175 | 56.5 | 1480 | 86 | 160 | 6 | 1590 |
| | 900 | 250 | 50 | | | | | |
| | 1080 | 300 | 44 | | | | | |

尺寸图DIMENSION FIGURE

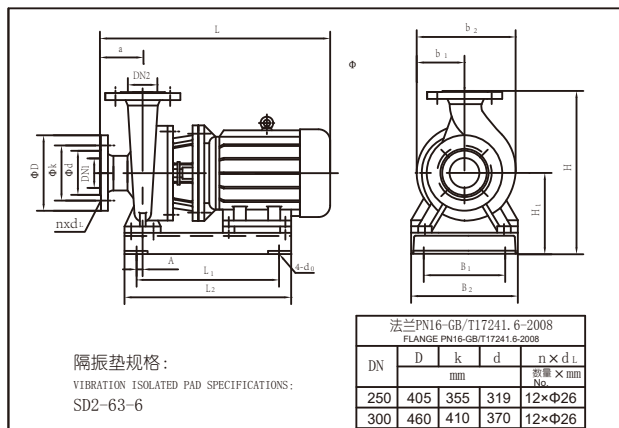

KQW尺寸表DIMENSION TABLE

| 型号 TYPE | 外形尺寸 Figure dimensions | | | | 安装尺寸 Installing dimensions | | | | | | | | | | DN1 | DN2 |
|--------------------|---------------------------|------|----------------|----------------|-------------------------------|-----|----------------|----------------|----------------|----------------|----------------|-----|-----|-----|-----|-----|
| | L | H | b ₂ | b ₁ | 4-φ ₀ | a | L ₁ | B ₁ | L ₂ | B ₂ | H ₁ | A | | | | |
| 300KQW600-38-90/4 | 1355 | 1134 | 674 | 320 | 4-φ25 | 250 | 800 | 550 | 1025 | 640 | 484 | 30 | 300 | 300 | | |
| 300KQW660-44-110/4 | 1600 | 1134 | 674 | 320 | 4-φ25 | 250 | 850 | 550 | 1090 | 640 | 484 | 30 | 300 | 300 | | |
| 300KQW720-50-132/4 | 1630 | 1134 | 674 | 320 | 4-φ25 | 250 | 950 | 550 | 1195 | 640 | 484 | 30 | 300 | 300 | | |
| 300KQW620-60-160/4 | 1630 | 1400 | 835 | 390 | 4-φ25 | 250 | 900 | 625 | 1185 | 720 | 600 | 30 | 300 | 300 | | |
| 300KQW670-70-200/4 | 1620 | 1400 | 835 | 390 | 4-φ25 | 250 | 900 | 625 | 1185 | 720 | 600 | 30 | 300 | 300 | | |
| 300KQW720-80-250/4 | 1840 | 1382 | 846 | 400 | 4-φ25 | 250 | 1020 | 650 | 1315 | 750 | 582 | 30 | 300 | 300 | | |
| 300KQW820-17-55/4 | 1220 | 1119 | 695 | 300 | 4-φ25 | 250 | 850 | 550 | 1015 | 640 | 519 | 50 | 300 | 300 | | |
| 300KQW820-24-75/4 | 1318 | 1081 | 695 | 300 | 4-φ25 | 253 | 850 | 430 | 1015 | 640 | 481 | 110 | 300 | 300 | | |
| 300KQW900-28-90/4 | 1345 | 1119 | 720 | 323 | 4-φ25 | 250 | 900 | 550 | 1055 | 640 | 519 | 50 | 300 | 300 | | |
| 300KQW800-32-110/4 | 1550 | 1119 | 720 | 323 | 4-φ25 | 250 | 920 | 550 | 1090 | 640 | 519 | 50 | 300 | 300 | | |
| 300KQW800-36-110/4 | 1620 | 1179 | 980 | 450 | 4-φ25 | 290 | 900 | 550 | 1150 | 640 | 509 | 30 | 300 | 250 | | |
| 300KQW900-40-132/4 | 1650 | 1179 | 980 | 450 | 4-φ25 | 290 | 950 | 550 | 1195 | 640 | 509 | 30 | 300 | 250 | | |
| 300KQW900-50-160/4 | 1650 | 1179 | 980 | 450 | 4-φ25 | 290 | 950 | 550 | 1195 | 640 | 509 | 30 | 300 | 250 | | |

性能曲线 CHARACTERISTIC CURVE

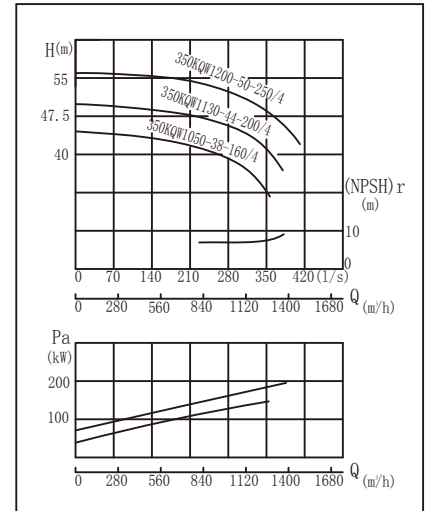
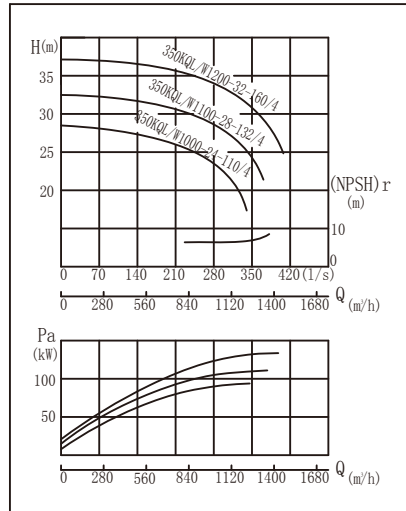
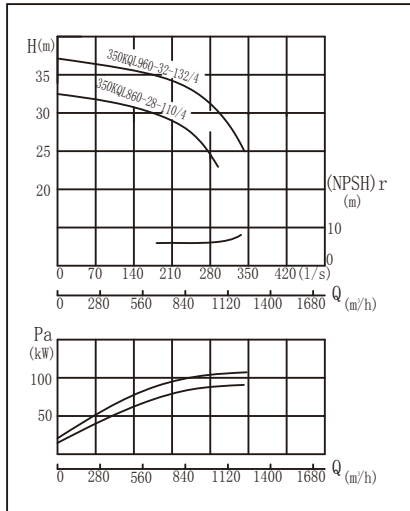

尺寸图 DIMENSION FIGURE

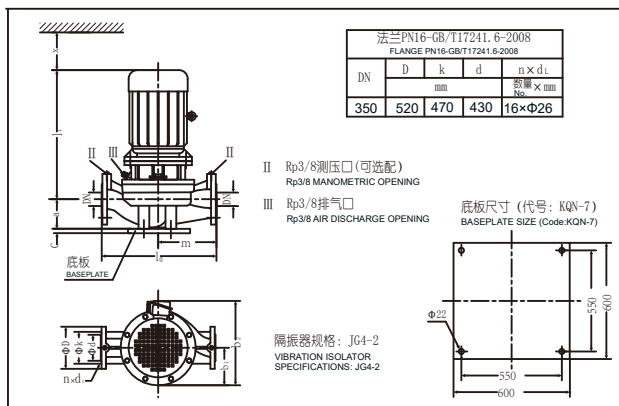

KQL尺寸表 DIMENSION TABLE

| 型号 TYPE | DN | l_0 | m | a | c | l_1 | b_1 | b_2 | x |
|---------------------|-----|-------|-----|-----|-----|-------|-------|-------|-----|
| | | mm | | | | | | | |
| 350KQL860-28-110/4 | 350 | 1350 | 600 | 470 | 45 | 1350 | 450 | 980 | 250 |
| 350KQL960-32-132/4 | 350 | 1350 | 600 | 470 | 45 | 1380 | 450 | 980 | 250 |
| 350KQL1000-24-110/4 | 350 | 1350 | 600 | 470 | 45 | 1350 | 450 | 980 | 250 |
| 350KQL1100-28-132/4 | 350 | 1350 | 600 | 470 | 45 | 1380 | 450 | 980 | 250 |
| 350KQL1200-32-160/4 | 350 | 1350 | 600 | 470 | 45 | 1380 | 450 | 980 | 250 |
| 350KQL720-11-37/6 | 350 | 1350 | 600 | 470 | 45 | 985 | 360 | 660 | 250 |
| 350KQL820-13-45/6 | 350 | 1350 | 600 | 470 | 45 | 1055 | 385 | 835 | 250 |

性能曲线CHARACTERISTIC CURVE

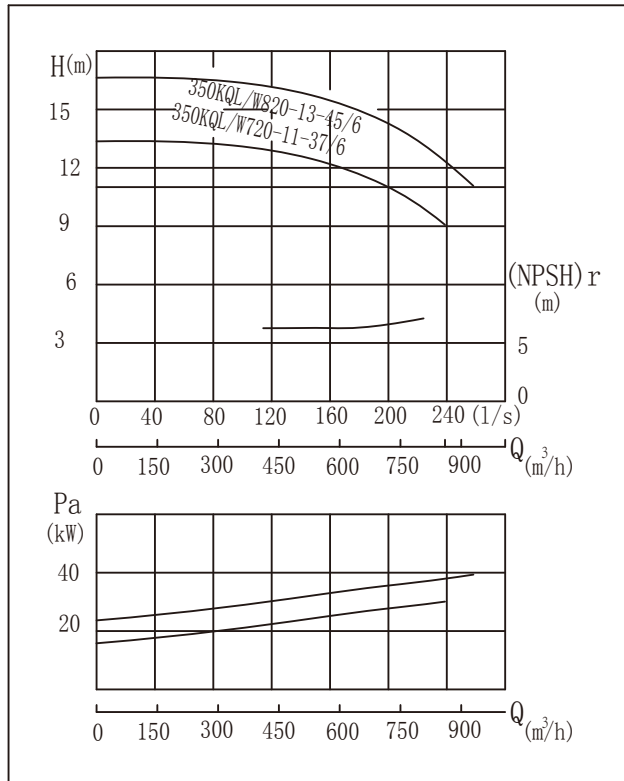

参数表PERFORMANCE DATA

| 型号 TYPE | 流量 Capacity | | 扬程 Head (m) | 转速 Speed (r/min) | 效率 Efficiency (%) | 电机 功率 Power (kW) | 必需汽蚀 余量 (NPSH)r (m) | 重量 Weight (kg) |
|-----------------------|----------------|-------|-------------------|------------------------|-------------------------|---------------------------|------------------------------|----------------------|
| | 3 (m³/h) | l/s) | | | | | | |
| 350KQL860-28-110/4 | 602 | 167 | 31 | 1480 | 80 | 110 | 8 | 1365 |
| | 860 | 239 | 28 | | | | | |
| | 1032 | 287 | 23 | | | | | |
| 350KQL960-32-132/4 | 672 | 187 | 35 | 1480 | 83 | 132 | 8 | 1452 |
| | 960 | 267 | 32 | | | | | |
| | 1152 | 320 | 27.5 | | | | | |
| 350KQL/W1000-24-110/4 | 750 | 208.3 | 27 | 1480 | 81 | 110 | 9 | 1335 |
| | 1000 | 277.8 | 24 | | | | | |
| | 1200 | 333.3 | 20 | | | | | |
| 350KQL/W1100-28-132/4 | 820 | 227.8 | 31 | 1480 | 83 | 132 | 9 | 1490 |
| | 1100 | 305.6 | 28 | | | | | |
| | 1300 | 361.1 | 23 | | | | | |
| 350KQL/W1200-32-160/4 | 900 | 250 | 36 | 1480 | 86.3 | 160 | 9 | 1870 |
| | 1200 | 333.3 | 32 | | | | | |
| | 1400 | 400 | 27 | | | | | |
| 350KQW1050-38-160/4 | 790 | 219.4 | 41 | 1480 | 81 | 160 | 9 | 1900 |
| | 1050 | 291.7 | 38 | | | | | |
| | 1225 | 340.3 | 32.7 | | | | | |
| 350KQW1130-44-200/4 | 850 | 236.1 | 46.6 | 1480 | 82 | 200 | 9 | 1930 |
| | 1130 | 313.9 | 44 | | | | | |
| | 1320 | 366.7 | 38 | | | | | |
| 350KQW1200-50-250/4 | 900 | 250 | 53 | 1480 | 83 | 250 | 9 | 2540 |
| | 1200 | 333.3 | 50 | | | | | |
| | 1400 | 400 | 44 | | | | | |
| 350KQL/W720-11-37/6 | 500 | 138.9 | 14 | 980 | 76 | 37 | 6.5 | 1208 |
| | 720 | 200 | 11 | | | | | |
| | 860 | 238.9 | 9 | | | | | |
| 350KQL/W820-13-45/6 | 574 | 159.4 | 16 | 980 | 78 | 45 | 6.5 | 1265 |
| | 820 | 227.8 | 13 | | | | | |
| | 930 | 258.3 | 11.5 | | | | | |

尺寸图DIMENSION FIGURE

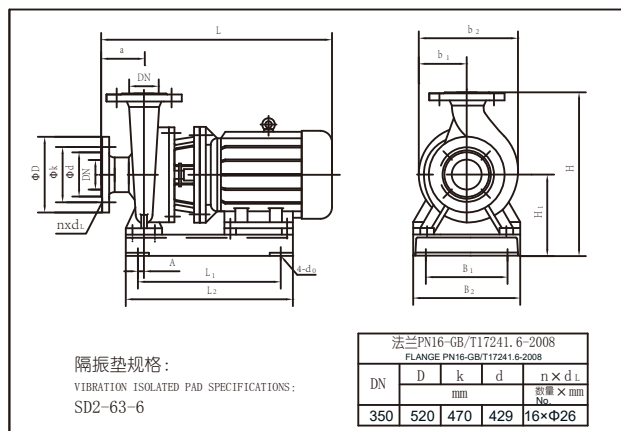

KQW尺寸表DIMENSION TABLE

| 型号 TYPE | 外形尺寸 Figure dimensions | | | | 安装尺寸 Installing dimensions | | | | | | | | | | DN |
|---------------------|---------------------------|------|----------------|----------------|-------------------------------|-----|----------------|----------------|----------------|----------------|----------------|----|-----|--|----|
| | L | H | b ₂ | b ₁ | 4-φ _{d0} | a | L ₁ | B ₁ | L ₂ | B ₂ | H ₁ | A | | | |
| 350KQW1000-24-110/4 | 1600 | 1117 | 720 | 323 | 4-φ25 | 250 | 920 | 550 | 1090 | 640 | 520 | 50 | 350 | | |
| 350KQW1100-28-132/4 | 1630 | 1117 | 720 | 323 | 4-φ25 | 250 | 1020 | 550 | 1200 | 640 | 520 | 50 | 350 | | |
| 350KQW1200-32-160/4 | 1630 | 1117 | 720 | 323 | 4-φ25 | 250 | 1020 | 550 | 1200 | 640 | 520 | 50 | 350 | | |
| 350KQW1050-38-160/4 | 1680 | 1267 | 785 | 360 | 4-φ25 | 270 | 1035 | 625 | 1235 | 720 | 567 | 50 | 350 | | |
| 350KQW1130-44-200/4 | 1680 | 1267 | 785 | 360 | 4-φ25 | 270 | 1035 | 625 | 1235 | 720 | 567 | 50 | 350 | | |
| 350KQW1200-50-250/4 | 1890 | 1251 | 825 | 400 | 4-φ25 | 270 | 1150 | 650 | 1355 | 750 | 551 | 50 | 350 | | |
| 350KQW720-11-37/6 | 1220 | 1120 | 720 | 325 | 4-φ25 | 250 | 750 | 550 | 940 | 640 | 520 | 50 | 350 | | |
| 350KQW820-13-45/6 | 1305 | 1120 | 720 | 325 | 4-φ25 | 250 | 800 | 550 | 985 | 640 | 520 | 50 | 350 | | |

附件及安装基础尺寸图表

ACCESSORIES AND INSTALLING BASIC DIMENSIONS CHART

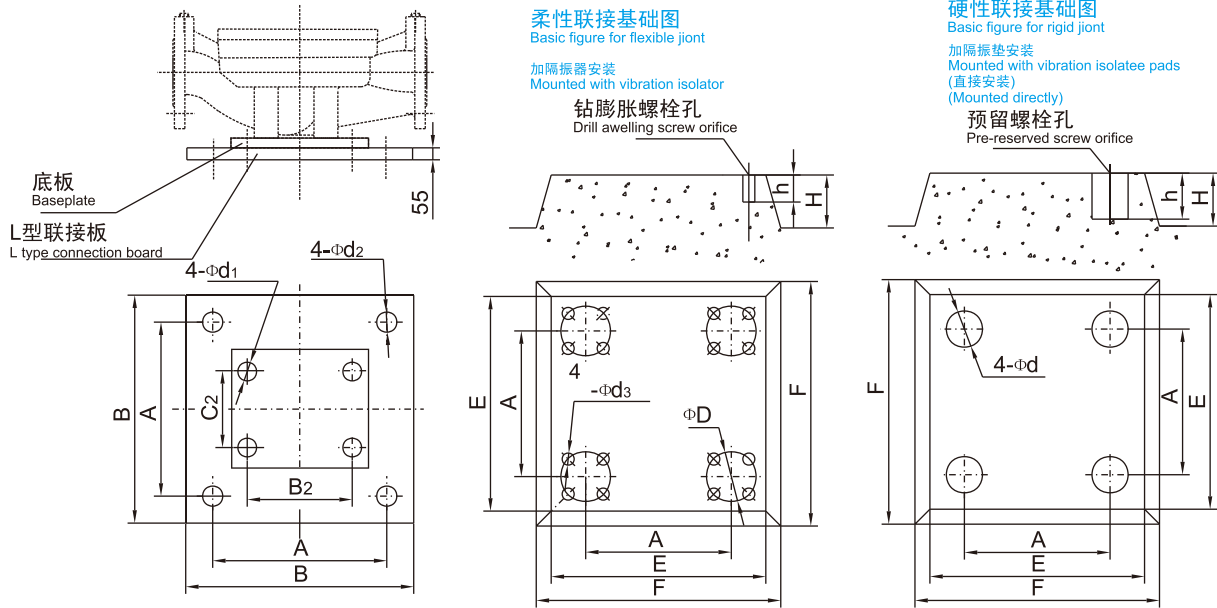

一、底板与基础直接联接（不带L型联接板）

I. Baseplate connected with base directly (without L type of connection board)

| 底板代号 Baseplate code (尺寸详见各尺寸图) (Dimensions appear in each figure) | Φd1 | 柔性联接基础尺寸图 Basic figure for flexible joint dimensions | | | | | | | 硬性联接基础尺寸图 Basic figure for rigid joint dimensions | | | | | | 地脚螺栓 GB799-88 |
|--|-----|---|------|------|-----|---|------|----|--|------|------|-----|----|-----|------------------|
| | | H | E | F | A | ΦD | Φd3 | h | H | E | F | A | d | h | |
| KQN-1 | 14 | 200 | 360 | 400 | 160 | 同 隔 振 器 D1 Just the same with D1 | 10.5 | 40 | 200 | 360 | 400 | 160 | 60 | 200 | M12×220 |
| KQN-2 | 14 | 200 | 400 | 450 | 210 | | 10.5 | 40 | 200 | 400 | 450 | 210 | 60 | 200 | |
| KQN-3 | 18 | 200 | 500 | 550 | 290 | | 14.5 | 60 | 300 | 500 | 550 | 290 | 80 | 300 | M16×300 |
| KQN-4 | 18 | 250 | 600 | 650 | 360 | | 14.5 | 60 | 300 | 600 | 650 | 360 | 80 | 300 | |
| KQN-5 | 22 | 250 | 650 | 700 | 400 | | 14.5 | 60 | 300 | 650 | 700 | 400 | 80 | 300 | M20×300 |
| KQN-6 | 22 | 300 | 800 | 900 | 450 | | 14.5 | 60 | 300 | 800 | 900 | 450 | 80 | 300 | |
| KQN-7 | 22 | 300 | 1000 | 1100 | 550 | | 14.5 | 60 | 300 | 1000 | 1100 | 550 | 80 | 300 | |

二、配L型联接板安装

II. Mounted with L type of connection board

| L型联接板尺寸 Dimensions of L type of connection board | | | | | 柔性联接基础尺寸图 Basic figure for flexible joint dimensions | | | | | | | 硬性联接基础尺寸图 Basic figure for rigid joint dimensions | | | | | | 地脚螺栓 GB799-88 | |
|---|---------|-----|-----|-----|---|-----|------|------|-----|---|------|--|------|------|------|-----|-----|------------------|---------|
| 型号 Type | C2xB2 | A | B | Φd1 | Φd2 | H | E | F | A | ΦD | Φd3 | h | H | E | F | A | Φd | | h |
| L-0 | 60x100 | 240 | 300 | 14 | 14 | 200 | 450 | 500 | 240 | 同 隔 振 器 D1 Just the same with D1 | 10.5 | 40 | 200 | 450 | 500 | 240 | 60 | 200 | M12×220 |
| L-1 | 160x160 | 240 | 300 | 14 | 14 | 200 | 450 | 500 | 240 | | 10.5 | 40 | 200 | 450 | 500 | 240 | 60 | 200 | |
| L-2 | 210x210 | 340 | 400 | 14 | 14 | 200 | 650 | 700 | 340 | | 10.5 | 40 | 200 | 650 | 700 | 340 | 80 | 200 | M16×300 |
| L-3 | 290x290 | 440 | 500 | 18 | 18 | 300 | 750 | 800 | 440 | | 10.5 | 40 | 300 | 750 | 800 | 440 | 80 | 300 | |
| L-4 | 360x360 | 540 | 600 | 18 | 18 | 300 | 850 | 900 | 540 | | 14.5 | 60 | 300 | 850 | 900 | 540 | 80 | 300 | M20×300 |
| L-5 | 400x400 | 640 | 700 | 22 | 22 | 300 | 950 | 1000 | 640 | | 14.5 | 60 | 300 | 950 | 1000 | 640 | 80 | 300 | |
| L-6 | 450x450 | 740 | 800 | 22 | 22 | 350 | 1100 | 1200 | 740 | | 14.5 | 60 | 350 | 1000 | 1100 | 740 | 80 | 300 | |
| L-7 | 550x550 | 840 | 900 | 22 | 22 | 350 | 1200 | 1300 | 840 | 14.5 | 60 | 350 | 1200 | 1300 | 840 | 80 | 300 | | |

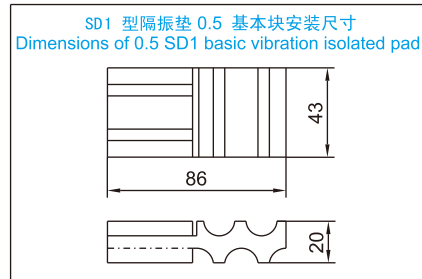
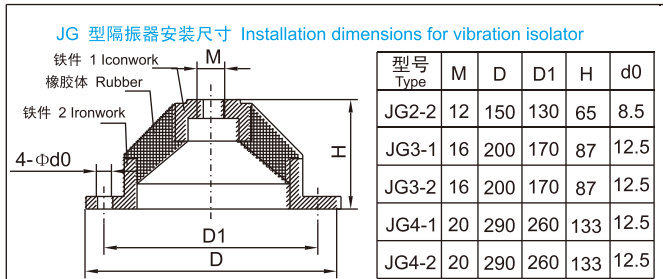

- 注：1. 本公司产品经精心加工装配，振动小。故建议一般不采用安装隔振器、隔振垫。各尺寸图中所注隔振器（垫）规格为推荐规格。
2. 一般情况下，推荐采用底板与基础直接联接方式。
Note: 1. Kaiquan product features less vibration due to elaborate machinery and assembly. It is recommended not to employ vibration isolator or isolated pads. The specifications of each dimension figure are recommended.
2. In general, it is recommended to baseplate connected with base directly.

KQL 允许的安装方式 INSTALLATION MODE

1. 直接安装 (7.5KW以下)
Direct installation

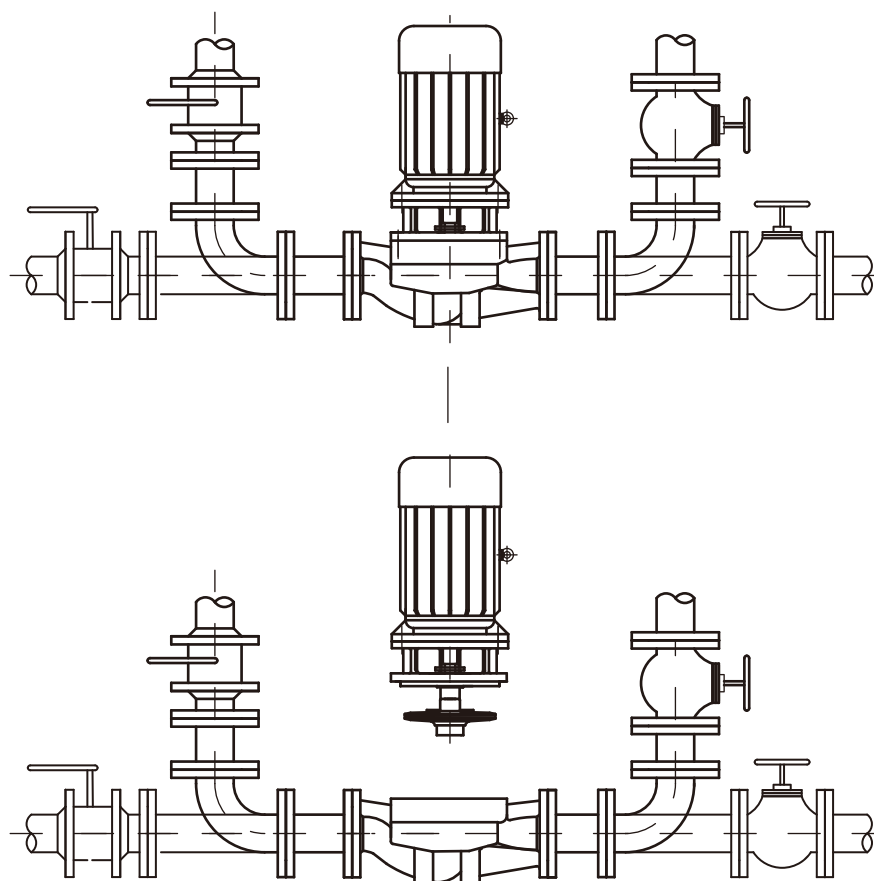

2. 地基支撑硬性联接
Rigid joint with base support

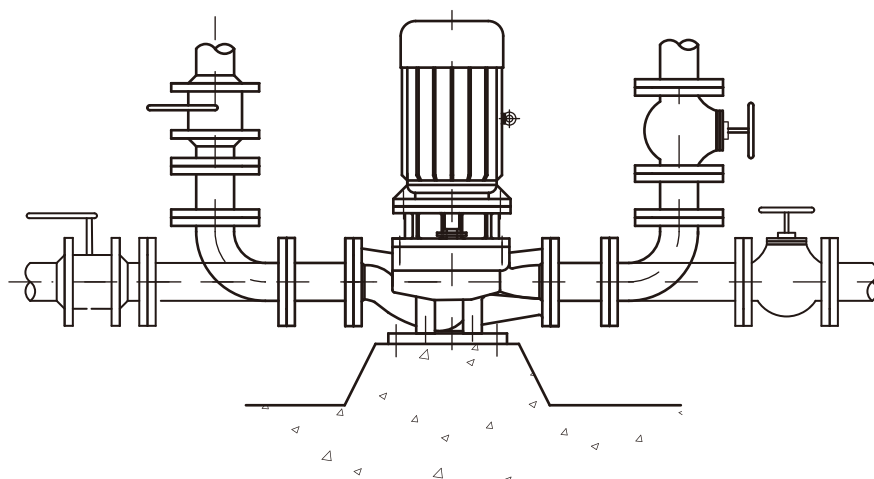

3. 地基支撑柔性联接
Flexible joint with base support

3.1 配底板加隔振器
Installed with baseplate and vibration isolator

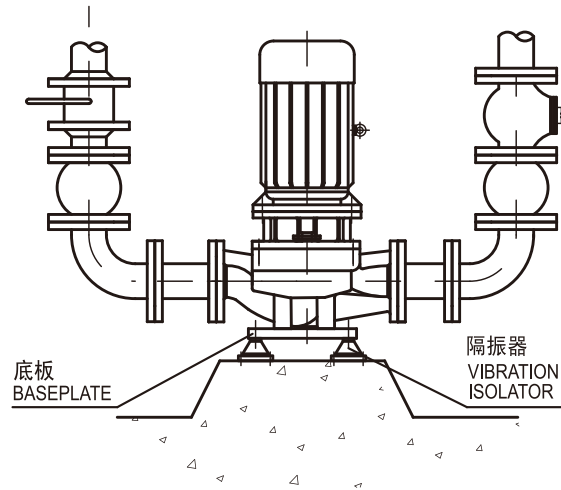

3.2 配底板加隔振垫
Installed with baseplate and vibration isolated pads

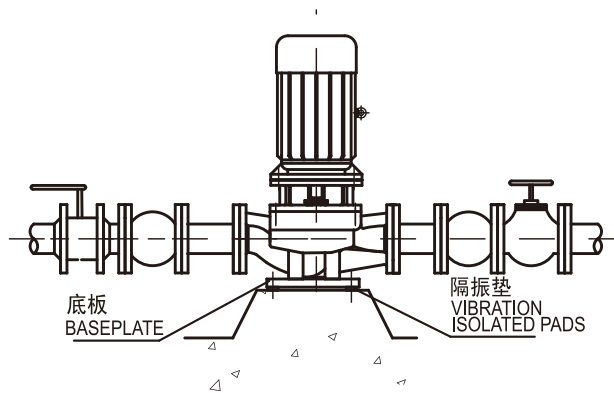

4. 悬臂卧式安装 (7.5KW以下)
Cantilever horizontal

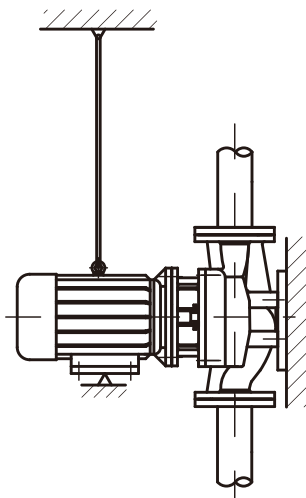

5. 户外使用: 采用户外电机
For outdoor usage: Adopt outdoor type motor

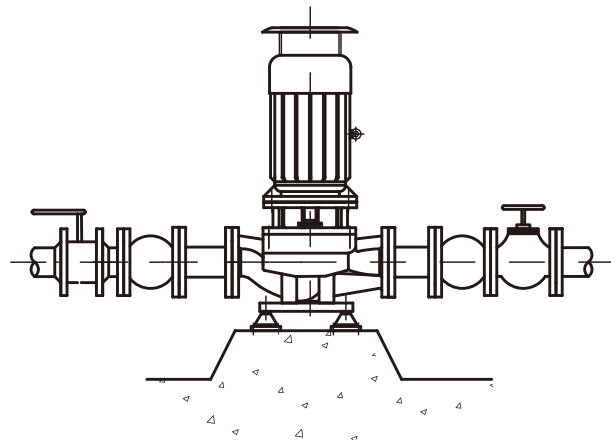

与原型号对照表

| 序号 | 型 号 | 原 型 号 | 序号 | 型 号 | 原 型 号 |
|----|------------------------|-------------------|----|------------------------|------------------|
| 1 | 50KQL/W11-10-0.75/2 | 50/90-0.75/2 | 49 | 100KQL/W100-12.5-5.5/2 | 100/100-5.5/2 |
| 2 | 50KQL/W12.5-12.5-1.1/2 | 50/100-1.1/2 | 50 | 100KQL/W85-16-5.5/2 | 100/110S-5.5/2 |
| 3 | 50KQL/W11-16-1.1/2 | 50/110-1.1/2 | 51 | 100KQL/W95-20-7.5/2 | 100/125S-7.5/2 |
| 4 | 50KQL/W12.5-20-1.5/2 | 50/125-1.5/2 | 52 | 100KQL/W80-24-7.5/2 | 100/140S-7.5/2 |
| 5 | 50KQL/W10-27-1.5/2 | 50/150S-1.5/2 | 53 | 100KQL/W94-28-11/2 | 100/150-11/2 |
| 6 | 50KQL/W12.5-32-2.2/2 | 50/160S-2.2/2 | 54 | 100KQL/W100-32-15/2 | 100/160-15/2 |
| 7 | 50KQL/W10-36-3/2 | 50/170S-3/2 | 55 | 100KQL/W115-34-15/2 | 100/165-15/2 |
| 8 | 50KQL/W12-44-4/2 | 50/185S-4/2 | 56 | 100KQL/W94-44-18.5/2 | 100/185-18.5/2 |
| 9 | 50KQL/W12.5-50-5.5/2 | 50/200S-5.5/2 | 57 | 100KQL/W100-50-22/2 | 100/200-22/2 |
| 10 | 65KQL/W22-10-1.1/2 | 65/90-1.1/2 | 58 | 100KQL/W87-60-30/2 | 100/220-30/2 |
| 11 | 65KQL/W25-12.5-1.5/2 | 65/100-1.5/2 | 59 | 100KQL/W94-70-30/2 | 100/235-30/2 |
| 12 | 65KQL/W22-16-2.2/2 | 65/110-2.2/2 | 60 | 100KQL/W100-80-37/2 | 100/250-37/2 |
| 13 | 65KQL/W25-20-2.2/2 | 65/125S-2.2/2 | 61 | 100KQL/W82-85-37/2 | 100/270-37/2 |
| 14 | 65KQL/W20-24-2.2/2 | 65/140S-2.2/2 | 62 | 100KQL/W90-101-45/2 | 100/285-45/2 |
| 15 | 65KQL/W23-28-3/2 | 65/150S-3/2 | 63 | 100KQL/W95-113-55/2 | 100/300-55/2 |
| 16 | 65KQL/W25-32-4/2 | 65/160-4/2 | 64 | 100KQL/W100-125-75/2 | 100/315-75/2 |
| 17 | 65KQL/W22-38-5.5/2 | 65/170S-5.5/2 | 65 | 100KQL/W50-8-2.2/4 | 100/160-2.2/4 |
| 18 | 65KQL/W23-44-5.5/2 | 65/185S-5.5/2 | 66 | 100KQL/W45-10-2.2/4 | 100/185-2.2/4 |
| 19 | 65KQL/W25-50-7.5/2 | 65/200S-7.5/2 | 67 | 100KQL/W50-12.5-3/4 | 100/200-3/4 |
| 20 | 80KQL/W45-10-2.2/2 | 80/90-2.2/2 | 68 | 100KQL/W47-17-4/4 | 100/235-4/4 |
| 21 | 80KQL/W50-12.5-3/2 | 80/100-3/2 | 69 | 100KQL/W50-20-5.5/4 | 100/250-5.5/4 |
| 22 | 80KQL/W45-16-3/2 | 80/110S-3/2 | 70 | 100KQL/W47-28-7.5/4 | 100/300-7.5/4 |
| 23 | 80KQL/W50-20-4/2 | 80/125S-4/2 | 71 | 100KQL/W50-32-11/4 | 100/315-11/4 |
| 24 | 80KQL/W40-24-4/2 | 80/140S-4/2 | 72 | 125KQL/W143-10-7.5/2 | 125/90-7.5/2 |
| 25 | 80KQL/W47-28-5.5/2 | 80/150S-5.5/2 | 73 | 125KQL/W160-12.5-11/2 | 125/100-11/2 |
| 26 | 80KQL/W50-32-7.5/2 | 80/160-7.5/2 | 74 | 125KQL/W143-16-11/2 | 125/110-11/2 |
| 27 | 80KQL/W35-34-5.5/2 | 80/165-5.5/2 | 75 | 125KQL/W160-20-15/2 | 125/125-15/2 |
| 28 | 80KQL/W44-38-7.5/2 | 80/170-7.5/2 | 76 | 125KQL/W138-24-15/2 | 125/140-15/2 |
| 29 | 80KQL/W47-44-11/2 | 80/185-11/2 | 77 | 125KQL/W150-28-18.5/2 | 125/150-18.5/2 |
| 30 | 80KQL/W50-50-15/2 | 80/200-15/2 | 78 | 125KQL/W160-32-22/2 | 125/160-22/2 |
| 31 | 80KQL/W43-60-15/2 | 80/220-15/2 | 79 | 125KQL/W138-38-22/2 | 125/170-22/2 |
| 32 | 80KQL/W47-70-18.5/2 | 80/235-18.5/2 | 80 | 125KQL/W150-44-30/2 | 125/185-30/2 |
| 33 | 80KQL/W50-80-22/2 | 80/250-22/2 | 81 | 125KQL/W160-50-37/2 | 125/200-37/2 |
| 34 | 80KQL/W40-85-22/2 | 80/270-22/2 | 82 | 125KQL/W138-60-37/2 | 125/220-37/2 |
| 35 | 80KQL/W43-101-30/2 | 80/285-30/2 | 83 | 125KQL/W150-70-45/2 | 125/235-45/2 |
| 36 | 80KQL/W47-113-30/2 | 80/300-30/2 | 84 | 125KQL/W160-80-55/2 | 125/250-55/2 |
| 37 | 80KQL/W50-125-37/2 | 80/315-37/2 | 85 | 125KQL/W134-88-55/2 | 125/270-55/2 |
| 38 | 80KQL/W25-20-3/4 | 80/250-3/4 | 86 | 125KQL/W143-100-75/2 | 125/285-75/2 |
| 39 | 80KQL/W23-28-4/4 | 80/300-4/4 | 87 | 125KQL/W150-110-75/2 | 125/300-75/2 |
| 40 | 80KQL/W25-32-5.5/4 | 80/315-5.5/4 | 88 | 125KQL/W160-125-90/2 | 125/315-90/2 |
| 41 | 100KQL/W60-16-4/2 | 100/110-4/2(Z) | 89 | 125KQL/W100-5-2.2/4 | 125/125-2.2/4 |
| 42 | 100KQL/W70-20-5.5/2 | 100/125-5.5/2(Z) | 90 | 125KQL/W87-6-3/4 | 125/150-3/4 |
| 43 | 100KQL/W70-26-7.5/2 | 100/150-7.5/2(Z) | 91 | 125KQL/W100-8-4/4 | 125/160-4/4 |
| 44 | 100KQL/W75-32-11/2 | 100/160-11/2(Z) | 92 | 125KQL/W100-12.5-5.5/4 | 125/200-5.5/4 |
| 45 | 100KQL/W68-38-11/2 | 100/170-11/2(Z) | 93 | 125KQL/W87-15-5.5/4 | 125/220-5.5/4 |
| 46 | 100KQL/W72-44-15/2 | 100/185-15/2(Z) | 94 | 125KQL/W93-17-7.5/4 | 125/235-7.5/4 |
| 47 | 100KQL/W75-50-18.5/2 | 100/200-18.5/2(Z) | 95 | 125KQL/W120-16-7.5/4 | 125/235(I)-7.5/4 |
| 48 | 100KQL/W89-10-4/2 | 100/90-4/2 | 96 | 125KQL/W100-20-11/4 | 125/250-11/4 |

与原型号对照表

| 序号 | 型 号 | 原 型 号 | 序号 | 型 号 | 原 型 号 |
|-----|-------------------------|-------------------|-----|-----------------------|----------------------|
| 97 | 125KQL/W79-20-7.5/4 | 125/285-7.5/4 | 145 | 200KQL/W340-24-30/4 | 200/285S-30/4 |
| 98 | 125KQL/W91-27-11/4 | 125/300-11/4 | 146 | 200KQL/W360-28-37/4 | 200/300S-37/4 |
| 99 | 125KQL/W100-32-15/4 | 125/315-15/4 | 147 | 200KQL/W390-32-45/4 | 200/315S-45/4 |
| 100 | 125KQL/W87-38-18.5/4 | 125/345-18.5/4 | 148 | 200KQL/W440-32-55/4 | 200/315-55/4 |
| 101 | 125KQL/W94-44-22/4 | 125/370-22/4 | 149 | 200KQL/W340-36-45/4 | 200/345S-45/4 |
| 102 | 125KQL/W100-50-30/4 | 125/400-30/4 | 150 | 200KQL/W370-40-55/4 | 200/350-55/4 |
| 103 | 150KQL/W140-20-11/4 | 150/250-11/4(Z) | 151 | 200KQL/W374-44-75/4 | 200/370-75/4 |
| 104 | 150KQL/W160-24-15/4 | 150/285-15/4(Z) | 152 | 200KQL/W400-50-75/4 | 200/400-75/4 |
| 105 | 150KQL/W150-28-18.5/4 | 150/300-18.5/4(Z) | 153 | 200KQL/W346-60-90/4 | 200/410-90/4 |
| 106 | 150KQL/W160-32-22/4 | 150/315-22/4(Z) | 154 | 200KQL/W374-70-110/4 | 200/435-110/4 |
| 107 | 150KQL/W138-38-22/4 | 150/345-22/4(Z) | 155 | 200KQL/W400-80-132/4 | 200/460-132/4 |
| 108 | 150KQL/W150-44-30/4 | 150/370-30/4(Z) | 156 | 250KQL/W490-17-30/4 | 250/235S-30/4 |
| 109 | 150KQL/W160-50-37/4 | 150/400-37/4(Z) | 157 | 250KQL/W520-20-37/4 | 250/250S-37/4 |
| 110 | 150KQL/W179-10-11/4 | 150/185-11/4 | 158 | 250KQL/W500-25-45/4 | 250/290-45/4 |
| 111 | 150KQL/W200-12.5-11/4 | 150/200S-11/4 | 159 | 250KQL/W500-28-55/4 | 250/300-55/4 |
| 112 | 150KQL/W180-16-11/4 | 150/235S-11/4 | 160 | 250KQL/W550-32-75/4 | 250/315-75/4 |
| 113 | 150KQL/W200-20-15/4 | 150/250S-15/4 | 161 | 250KQL/W500-41-75/4 | 250/350-75/4 |
| 114 | 150KQL/W173-24-18.5/4 | 150/285-18.5/4 | 162 | 250KQL/W500-44-90/4 | 250/370-90/4 |
| 115 | 150KQL/W200-28-22/4 | 150/290-22/4 | 163 | 250KQL/W500-50-90/4 | 250/400S-90/4 |
| 116 | 150KQL/W200-32-30/4 | 150/315-30/4 | 164 | 250KQL/W600-50-110/4 | 250/400-110/4 |
| 117 | 150KQL/W240-32-30/4 | 150/315(I)-30/4 | 165 | 250KQL/W480-60-132/4 | 250/410-132/4 |
| 118 | 150KQL/W200-38-30/4 | 150/350-30/4 | 166 | 250KQL/W515-70-160/4 | 250/435-160/4 |
| 119 | 150KQL/W187-44-37/4 | 150/370-37/4 | 167 | 250KQL/W550-80-200/4 | 250/460-200/4 |
| 120 | 150KQL/W200-50-45/4 | 150/400-45/4 | 168 | 300KQL/W660-18-45/4 | 300-200A-45/4 |
| 121 | 150KQL/W173-60-55/4 | 150/410-55/4 | 169 | 300KQL/W720-20-55/4 | 300-200-55/4 |
| 122 | 150KQW180-70-55/2 | KQW150/235-55/2 | 170 | 300KQL/W600-24-55/4 | 300-315B-55/4 |
| 123 | 150KQL/W187-70-75/4 | 150/435-75/4 | 171 | 300KQL/W660-28-75/4 | 300-315A-75/4 |
| 125 | 150KQW200-80-75/2 | KQW150/250-75/2 | 172 | 300KQL/W720-32-90/4 | 300-315-90/4 |
| 125 | 150KQL/W200-80-75/4 | 150/460-75/4 | 173 | 300KQL/W600-38-90/4 | 300-400B-90/4(N) |
| 126 | 200KQL/W280-10-11/4 | 200/185S-11/4(Z) | 174 | 300KQL/W660-44-110/4 | 300-400A-110/4(N) |
| 127 | 200KQL/W300-12.5-15/4 | 200/200S-15/4(Z) | 175 | 300KQL/W720-50-132/4 | 300-400-132/4(N) |
| 128 | 200KQL/W280-16-18.5/4 | 200/235-18.5/4(Z) | 176 | 300KQW620-60-160/4 | 300-500B-160/4 |
| 129 | 200KQL/W300-20-22/4 | 200/250S-22/4(Z) | 177 | 300KQW670-70-200/4 | 300-500A-200/4 |
| 130 | 200KQL/W245-24-22/4 | 200/285S-22/4(Z) | 178 | 300KQW720-80-250/4 | 300-500-250/4 |
| 131 | 200KQL/W280-28-30/4 | 200/300S-30/4(Z) | 179 | 350KQL/W1000-24-110/4 | 350-315B-110/4 |
| 132 | 200KQL/W300-32-37/4 | 200/315S-37/4(Z) | 180 | 350KQL/W1100-28-132/4 | 350-315A-132/4 |
| 133 | 200KQL/W260-38-45/4 | 200/345-45/4(Z) | 181 | 350KQL/W1200-32-160/4 | 350-315-160/4 |
| 134 | 200KQL/W270-44-45/4 | 200/370S-45/4(Z) | 182 | 300KQL/W820-24-75/4 | 300-315A-75/4 |
| 135 | 200KQL/W300-48-55/4 | 200/400S-55/4(Z) | 183 | 350KQL860-28-110/4 | 350-315A-110/4(Z) |
| 136 | 200KQL/W262-60-75/4 | 200/410-75/4(Z) | 184 | 350KQL960-32-132/4 | 350-315-132/4(Z) |
| 137 | 200KQW262-70-75/2 | KQW200/235-75/2 | 185 | 350KQW1050-38-160/4 | 350-400B-160/4(N) |
| 138 | 200KQL/W280-70-90/4 | 200/435-90/4(Z) | 186 | 350KQW1130-44-200/4 | 350-400A-200/4(N) |
| 139 | 200KQW290-80-90/2 | KQW200/250-90/2 | 187 | 350KQW1200-50-250/4 | 350-400-250/4(N) |
| 140 | 200KQL/W300-80-110/4 | 200/460-110/4(Z) | 188 | 350KQL/W820-38-132/4 | 350-400B-132/4(Z)(N) |
| 141 | 200KQL/W358-10-15/4 | 200/185S-15/4 | 189 | 350KQL/W860-44-160/4 | 350-400A-160/4(Z)(N) |
| 142 | 200KQL/W400-12.5-18.5/4 | 200/200S-18.5/4 | 190 | 350KQL/W960-50-200/4 | 350-400-200/4(Z)(N) |
| 143 | 200KQL/W358-16-22/4 | 200/235-22/4 | | | |
| 144 | 200KQL/W400-20-30/4 | 200/250-30/4 | | | |